

# SECTION 2

## COUNTRY PLEASURE, OPEN GAITED BREED AND VERSATILITY

Chapter 10	Judging Specifics for Country Pleasure (CP) .....	2-1
Chapter 11	Judging Specifics for Open Gaited Breeds (OGB) .....	2-2
Chapter 12	Versatility Class Descriptions and Specifications .....	2-8
In Hand	V101 Showmanship .....	2-8
Technical One	V102 Barrel Racing .....	2-9
	V103 Equitation – Saddle Seat and Stock Seat .....	2-9
	V104 Water Glass .....	2-10
	V105 Pole Bending .....	2-10
	V106 Western Riding .....	2-11
	V107 EquiTheater .....	2-12
Technical Two	V108 Dressage .....	2-12
	V109 Pleasure Driving .....	2-13
	V110 Freestyle Reining .....	2-14
	V111 Over Fences and Jumping .....	2-14
	V112 Natural Horsemanship .....	2-15
	V113 Reining .....	2-15
	V114 Trail Obstacle .....	2-20
Technical Three	V115 Trail Trial .....	2-20

## Chapter 10: Judging Specifics for Country Pleasure Division (CP)

The IJA Rule Book does not restrict or prohibit cross entries between Divisions. However, show management has the right to limit or prohibit cross entries between any Divisions and breed specific Country Pleasure Classes or any Division and Open Gaited Breed Country Pleasure Classes.

### CP 100 Country Pleasure Division

- Country Pleasure Classes may be breed specific or Open Gaited Breed.
- Country Pleasure classes may be two or three gait.
- The intermediate gait is the choice of the exhibitor, but the intermediate gait may not be the canter, lope or hand gallop.
- Unless show managers direct otherwise, country pleasure horses are eligible to compete in any other class at the show as long as their shoeing conforms to requirements of the class.
- The ideal country pleasure horse should reflect the name of the division. This should be the type of horse that you would willingly ride if you were to go out to spend a day in the country.
- In Country Pleasure classes, correctness of gait is not evaluated.

### Performance and way of going

- The horse has the ability and the fitness level to travel all day over a variety of terrain.
- The horse has the mental ability to travel all day over a variety of terrain.
- The horse needs little or no encouragement to move forward at a constant speed.
- The horse displays exceptional manners.
- The horse exhibits an alert and willing attitude.
- The horse and rider are in tune with each other.
- There is no need for an excessively tight rein.
- The horse is not held in frame.
- The horse is pleasant, confident and obedient.
- The horse has a quiet nature but is responsive to the rider's commands.
- The horse has a smooth and comfortable "saddle gait".
- The horse is calm.
- Horses line up and stand quietly before being asked to back.
- The judge will ask that the rider slowly feed the rein to the horse at the walk and walk on a loose rein until the judge asks that the rein be picked up.
- The judge may ask for a halt on the rail from any gait.
- The judge may require exhibitors to mount and dismount while in the lineup.

### Penalties

- Lack of stamina or condition will be **severely penalized**.
- Excessive speed or animation that is not compatible with a "stroll in the country" will be **severely penalized**.
- Excessive spurring or kicking to encourage the horse to stay in gait will be **severely penalized**.
- Excessively tight reins will be **severely penalized**.
- Horses held in frame will be **severely penalized**.
- Any sign of resistance will be **penalized**.
- Pinned ears will be **penalized**.
- Twitching tails will be **penalized**.
- Lack of forward motion will be **penalized**.

### Call of class for Country Pleasure

- In order to accommodate all gaited breeds, horses enter the ring at the walk specific to each individual breed.
- The intermediate gait excludes the canter, lope or gallop.
- The judge will ask that the rider slowly feed the rein to the horse and walk on a loose rein.

- The judge may ask for a halt on the rail from any gait.

**Two Gait classes** – breed specific walk, intermediate gait, breed specific walk, reverse, breed specific walk, intermediate gait, breed specific walk, and proceed to the line-up at the gait of judge's choice.

**Three Gait classes** – breed specific walk, intermediate gait, breed specific walk, canter or lope, breed specific walk, reverse, breed specific walk, Intermediate gait, breed specific walk, canter or lope, breed specific walk, and proceed to the line-up at the gait of judge's choice.

### Shoeing

Country Pleasure horses are not defined by shoe size but by way of going. Any shoe that is legal under IJA rules is allowed (see breed rules as well as **Chapter 4**). Horses may also compete in keg shoes or barefoot if the way of going is appropriate for the class.

### Tack and attire

- Country Pleasure classes may be English or Western.
- Traditional tack and Attire is permissible.
- Optional Tack is permissible.
- Show management may determine if alternate attire (clean, neat and safe trail attire) is permissible.
- In all cases tack and attire must match.

For complete description refer to **606, 608, 638, and 645**

# Chapter 11: Judging Specifics for Open Gaited Breed Division (OGB)

The IJA Rule Book does not restrict or prohibit cross entries between Divisions. However, show management has the right to limit or prohibit cross entries between any Divisions and breed specific Country Pleasure Classes or any Division and Open Gaited Breed Country Pleasure Classes.

## Open Gaited Breed Division

### OGB 100 General

- Open Gaited Breed Classes may be offered at any FOSH sanctioned event.
- Any Gaited Breed is eligible to enter as long as they conform to the general IJA shoeing requirements as outlined in Chapter 4.
- Show management may offer a variety of Open Gaited Breed classes including but not limited to In Hand, English, Trail Pleasure, Working Trail Pleasure, English Equitation (Saddle Seat or Hunt Seat) Stock Seat Equitation, Western Pleasure, Ranch Horse and Country Pleasure. All classes may be further described as 2 gait, 3 gait, youth, adult, novice horse, novice rider, novice horse and rider, open, amateur, amateur owned and trained, amateur owned trained and ridden, age restricted for either horse or rider etc. **The call of the gait will vary with the class.**
- **Three Gait Classes may be with canter or without canter. Some gaited breeds do not canter, but perform three gaits.**
- Versatility classes may be breed specific or Open Gaited Breed.
- When competing in Open Gaited Breed Classes traditional tack and attire may be used
- Horses registered in more than one registry may compete with tack and attire appropriate for one breed but not a combination of breeds.
- When competing in Open Gaited Breed classes, and if there is a discrepancy between the breed specific tack and attire rules and Chapter 6, exhibitors may choose which tack and attire rules they will follow.
- Ring Protocol and Judging Procedures will be as outlined in this Rule Book.

### Gaits for Open Gaited Breed Classes

- Horses enter the ring at the walk specific to the breed.
- The walk is of the exhibitor's choice, but is the walk specific to the breed.
- The working walk is a slow even four beat walk. The head and neck are lowered as the horse stretches into the rider's hand showing relaxation and acceptance of the bit. At the working walk the horse is calm and relaxed. There is no need for restraint on the part of the rider and there is observable slack in the reins.
- The intermediate gait is of the exhibitor's choice, but is the gait the breed considers the intermediate gait.
- The canter or lope is a three beat gait on the correct lead. The horse is under control.

### OGB 101 Open Gaited Breed In Hand

#### See 513 In Hand Class for Protocol

#### Conformation

When judging specific breeds, the registry requirements of the breed will be used.

#### Light Horse Type and Conformation

In general the ideal light horse should have a neat head, well shaped ears, large eyes, and a tapering muzzle. There should be clear definition at the throatlatch and no indication of coarseness. Nostrils should be wide and open. The jaw should be well defined. The neck should be of a length proportionate to the remainder of the body and should not be heavy/ common. Backs should tend towards the short with good coupling at the loins and should give the impression of strength in conformation. The chest should be of

adequate width to allow for ample lung capacity. The body should be deep in the girth and well ribbed. Croups should generally exhibit a gentle slope while the hips should be well muscled with the muscle extending down the leg towards the hocks. Legs should be flat and cordy and should be well situated on the corners of the horse. The horse's feet should be of a size sufficient to support the bulk of the body.

#### Common terms for evaluating Light Horses

**Topline:** The back of the horse viewed from the top is called the topline. It should be straight with muscle mass of equal symmetry in mature horses visible on the left and right sides. In order to evaluate the topline, the horse must be shown on the square with an equal amount of weight on all four feet and the nose positioned directly in front of the chest.

**Loin:** From a side view, the strong loin shows peaks or waves in the topline over the lumbosacral joint. A short loin will map out as a broad triangle from each lumbosacral joint. A short strong loin aids in the ability to collect the horse. A longish loin weakens the back irrespective of the body's overall length.

**Length of Back:** The length of the back is to be compared to the overall length of the total body as measured from the point of the shoulder to the point of the buttock.

**Withers:** The withers not only anchor the neck, it provides a leverage point that allows the back to rise or fall when the horse raises or lowers its head. Low withers predispose an animal to being unable to actively raise the back, thus creating a hollow back by conformation. High withers create problems with tying in the root of the neck.

**Neck:** The neck serves as the primary agent of balance for the horse. Although a long-necked horse may be attractive, in judging conformation, the excessively long neck is to be penalized because it precludes suppleness and leads to "rubber necking" or to resistance to collection. In determining an appropriate length of neck, envision an imaginary curved line drawn from just behind the ears of the horse to the dock of the tail.

**Forelegs:** If a horse is considered to be over at the knee he is standing too far backward; behind the knee means the horse is standing too far back. Both situations are weaknesses in conformation. If pigeon-toed, the feet turn in; when splayfooted the feet turn out.

**Hind leg:** Common faults of the hind legs include: too far under the horse- sickle hocked; turned in towards each other at the point of the hock- cow hocked; hocks turned out at the point of the hock, bowed hocks. The hind legs should be vertical at the cannon bone.

**Tractability:** The ease with which a horse may be managed, worked with, or handled; docility or malleability.

#### Tack and Attire

For complete description refer to **623, 624, 625, and 626** In Hand Tack, Equipment and Attire and **608** Prohibited Tack, Equipment and Attire

### OGB 102 Open Gaited Breed Lead-line (Youth 8 years & under)

- Designed to furnish youth exhibitors the opportunity to learn and demonstrate basics of horsemanship. Safety is of prime importance.
- The handlers of horses must be adults (18 years or older).
- Horses must be two years old or older.
- No stallions are permitted.
- Attire for this class may be English or Western, but not a combination of both. Exhibitor's feet must be in stirrups. The use of velcro, tape, or the tying of the youth's feet in the stirrups is strictly forbidden.
- Handler and rider's attire must be clean, neat, and uniform.
- A lead shank attached safely to the horses bridle OR a halter with an attached lead shank over the bridle is mandatory.
- Handler should allow sufficient slack in the lead to give ex-

# Chapter 11: Judging Specifics for Open Gaited Breed Division (OGB)

hibitor some control of the horse. Horse's grooming shall be considered in overall judging.

- Judging shall be based on the youth exhibitor's abilities.
- Show Management has the option of placing the Lead Line Class or awarding Blue to all exhibitors.

## Judging Criteria

### Appearance of Exhibitor and Handler (30 points)

- Suitable English or Western attire, but not a combination of both.
- **Cleanliness, neatness, and uniformity.**

### Youth exhibitor's performance (40 points)

- Correct seat position and poise
- Correct rein carriage and hand placement
- Alertness

Options judge may ask of the rider

- Backing their horse two to three steps
- Various general questions regarding the name of their horse, their age, their name, etc.
- Riding forward through cones. *In these cases, the handler retains a loose hold on the horse.*

### Appearance of Horse (20 points)

- Physical condition of horse
- Hair coat clean and well brushed
- Mane and tail tangle-free
- Hooves trimmed or properly shod
- Well trimmed ears, jaws, legs and pasterns

### Tack (10 points)

- Tack should be neat, clean and in good condition

### OGB 103 Open Gaited Breed Parade

- Parade classes may be designated Western, English, Period, Historical or open.
- No matter the classification, the purpose of the class is to entertain and dazzle.
- The Parade horse is a showy, stylish and animated entry displaying beauty and brilliance.
- The class will be accompanied by march music (if available) of the sort heard at parades.

### Performance and way of going

- There is a noticeable increase in speed between the animated walk and the parade gait.
- The neck is arched.
- The ears are active and alert.
- The horse demonstrates good manners.
- The horse is stylish and animated.

### To be Judged

- 75% on performance, style, appearance and manners
- 25% on appointments of the horse and rider.

### Call of Gait

Horses enter the ring at the animated walk. They are shown at the animated walk and the parade gait. They reverse at the walk.

- The **animated walk** is a four beat gait executed on a straight track with knee action appropriate to the breed.
- The **parade gait** is a straight, balanced, collected intermediate gait that allows the rider to sit comfortably while demonstrating the parade wave.

### Penalties

- excessive speed
- bad manners
- swishing of tail, sour ears, gaping of mouth
- hesitating
- zigzagging

### Shoeing

Parade horses are not defined by shoe size but by way of going. The lite

shod shoe is the maximum shoe allowed, but horses may compete with keg shoes or barefoot if the way of going is appropriate for the class.

### Tack and Attire

No matter the classification of the class, the purpose is to entertain and dazzle.

- Clothing and appointments may be decorated with sequins, rhinestones, or other decorative elements.
- Braids augmented with flowers or other elements may be used in the mane and/or at the tail.
- Glitter is allowed on the body of the horse and in the mane and tail.
- Glittering of the hooves is permitted.
- Polo wraps, non-weighted bell boots or combi boots may be used.
- Tie downs and martingales are not allowed.
- If the theme is **Western** or representative of the Old West entries may be shown in Western or charro attire, At a minimum a cowboy shirt, pants with chaps, or a formal cowboy suit, Western hat and boots, or in the case of ladies, optional sidesaddle attire is required. Spurs, decorative firearms, serapes, etc., are permitted.
- If the theme is **Period or Historical**, tack and attire should be appropriate to the period of history represented.
- If the theme is **English**, the tack and attire should be appropriate to the discipline (Saddle Seat, Hunt Seat, Dressage).

### OGB 104 Open Gaited Breed EquiTheater (Previously Horse Dancing) Description:

- EquiTheater is where each exhibitor creates and presents with their horse, an entertaining routine to the audience using: costumes, choreography, music, props, storytelling and acting. Routines may be serious, dramatic, elegant or funny.
- EquiTheater is not like any other musical horse sport, because it has fewer required elements, and the main emphasis of a routine is on its ENTERTAINMENT value, not on how well a horse performs.
- EquiTheater is not a Dressage Kur or a Freestyle Reining pattern. It is not stepping, prancing or dancing around in the arena, nor riding on the rail in a costume with background music. It is not a horse(s) at liberty act, nor a trick horse(s) act.
- The primary emphasis is to encourage exhibitors or all ages and all abilities and their horse(s) to have FUN with EquiTheater, and for EquiTheater to attract spectators.
- All exhibitors should understand that judging is very subjective.
- Although special tack or attire is not required, exhibitors must still adhere to the IJA rules for shoeing, shank length on bits and comply with all other IJA rules that promote the humane treatment of the horse (restrictions on action devices, severe bits, etc.)
- Show management may reserve the right to not accept an EquiTheater presentation that they do not consider suitable for any reason.
- Costuming, song and routine must all be "G" rated, suitable for a general, family oriented audience. For example nothing risqué, controversial, demeaning, derogatory, or using bad language is allowed. Use of the National flag is not allowed.
- Although costumes are an integral part of this class, safety for both horse and rider is of prime importance.
- For safety purposes, a "spotter" is allowed in the arena for beginning, young, fearful or handicapped exhibitors etc.
- A solo routine is one horse/one exhibitor; a duo routine is two horses/ two exhibitors; and a trio routine is three horses/ three exhibitors. Horses may be ridden, driven, in-hand (In-hand includes line driving), or any combination thereof. Each entry may

# Chapter 11: Judging Specifics for Open Gaited Breed Division (OGB)

use “extras” (people) to come and go, or to stay in the arena to serve as props, characters, or actors in the skit.

## Required Elements:

- While there are no time limits, guidelines are: each routine to be a maximum of 4 minutes; an additional 2 minutes in total is allowed for setting and dismantling props.
- The arena is considered is a stage and exhibitors should position their routine so they perform to the audience. The performance should have a balanced appearance.
- Riding in figure 8 type patterns, or riding exclusively on the rail will be penalized.
- The performance must include at least one stop and one back-up.
- The exhibitor must demonstrate at least 2 gaits, each gait in both directions of the ring.
- In addition to the other required elements, in-hand exhibitors must work off both sides of the horse. (In-Hand classes include Line Driving.)
- **To ensure performance is suitable, a written description of the presentation and music must be submitted with Entry fees.**

## When the numbers of Entries Warrant, Classes may be offered for:

- Any gaited breed either ridden, driven or In-Hand, or any combination there of. In-Hand classes include Line Driving
- Any age exhibitor
- Any age horse
- 2 or 3 gaits

## Judging Criteria:

- EquiTheater is judged by individual evaluation.
- The judge **must** sit in the audience for judging and **must** use the scoring sheet.
- Scoring criteria: **60% entertainment 40% required elements.**

## OGB 105 Open Gaited Breed Sidesaddle

### General

- Classes may be designated English or Western or Traditional Breed or open.
- English may be **Antebellum Sidesaddle** or **Open Sidesaddle**. Antebellum sidesaddle would require authentic attire and equipment to be of the “mid-1800’s Sidesaddle era”.
- Open sidesaddle would be sidesaddle attire appropriate to either English or Western equipment, to include hunt or pleasure attire.
- Traditional Breed sidesaddle would be sidesaddle tack and attire appropriate to the historical aspect of a specific breed.
- Classes may be 2 gait or 3 gait.
- Class procedure is the same as other rail classes.
- At the discretion of the judge horses may be asked to back.

## Judging Criteria:

- 50% on presentation, appointments and attire of the rider
- 50% on gait, manners and presentation of the horse.

## Appropriateness of Dress:

- Women of the sidesaddle era were conservative in dress, with trim skirts and fitted bodices.
- Bare arms, neck, shoulders or low necklines would be considered inappropriate, as well as hats with extreme brims, feathers or trimmings.
- Legs should be covered.
- Skirts should cover the stirrup and hang fluidly, without full petticoats or crinolines.

## Appropriate attire for either English or Western would include:

- Hat
- Gloves
- Trim bodice with long sleeves and high collar
- Long skirt or apron to cover the stirrup

- Riding jodhpurs or pants and boots. (Appropriate sidesaddle attire does not include bloomers, as those were considered “underwear”. Riding breeches were worn under the skirts).

## Sidesaddle Tack

- The saddle should be safe and of serviceable construction, with appropriate girths and safety girths.
- The saddle should be either English or Western, and not a combination of both. The saddle may be traditional to a specific breed.
- Bridles and accompanying tack should be of the same style as the saddle, either English or Western or traditional to a specific breed.
- A crop (or whip) may be carried on the off side by English attired riders.
- See **Chapter 6 Tack and Attire** for complete description.

## Shoeing

Sidesaddle Classes are not defined by shoe size but by way of going. The lite shod shoe is the maximum shoe allowed, but horses may compete with keg shoes or barefoot if the way of going is appropriate for the class.

## OGB 106 Open Gaited Breed Equitation

- The rider is judged in equitation classes.
- Equitation classes are traditionally Saddle Seat or Hunt Seat or Dressage Seat or Stock Seat. Such classes are designed for particular styles of riding and should be entered only by those who ride those styles.
- Some gaited breeds included in the IJA Rule Book and competing at FOSH sanctioned shows do not conform to traditional styles of riding (hunt seat, saddle seat, dressage seat, and stock seat). To accommodate all breeds of gaited horses and all styles of traditional riding, **OPEN** equitation classes for Open Gaited Breeds may be offered at FOSH sanctioned shows.
  - o These equitation classes are not designated English or Western: they are designated open.
  - o Any gaited breed with any type of tack and any style of riding is eligible to enter.
  - o There may be western classes where both one hand is used on the rein or two hands are used on the rein depending upon the traditional aspect of the breed.
  - o If the rider is riding in the traditional manner of the breed, the judge will make no distinction between one hand or two hands on the rein.
  - o As in all equitation classes, the rider will be judged.

## OGB 107 Open Gaited Breed Versatility Classes

- Versatility classes include: Showmanship at Halter, Barrel Racing, Equitation, Pole Bending, Water Glass, Western Riding, Dressage, Driving, Freestyle Reining, Over Fences and Jumping, Natural Horsemanship, Trail Obstacle, EquiTheater and Reining. **New for 2008 - Trail Trials, Judged Trail Rides, Competitive Trail, Endurance Rides, Ranch Horse Competition, Cattle Penning, Reining, Cutting, 3 Day Events, Cross Country Driving, Combined Driving.**
- **In addition to the above for the purposes of Versatility programs, Versatility classes include Halter, Model and open 2 and 3 gait rail classes.**
- All classes included in the Versatility section of the IJA Rule Book (**Chapter 12**) are open to all gaited breeds.

## OGB 108 Best Gaited Horse Class

- Any Gaited Breed is eligible to enter as long as the horse conforms to the general shoeing requirements as outlined in **Chapter 4**.
- Classes that may be offered include youth, adult, novice horse, novice rider, novice horse and rider, open, amateur, amateur owned and trained, amateur owned trained and ridden, age or

## Chapter 11: Judging Specifics for Open Gaited Breed Division (OGB)

gender restricted for either horse or rider etc. Classes may be offered as non-qualifying, qualifying, or championship classes, or as a stake class with no qualifying requirements.

- When competing in Open Gaited Breed Best Gaited Horse Classes, tack and attire traditional to the horse's breed may be used.
- Horses registered in more than one registry may compete with tack and attire appropriate for one breed, but not a combination of breeds.
- Although the class is judged on entries' ability to perform and maintain a properly executed gait, entries should present an overall picture of an ideal pleasure gaited horse. Horses with bad manners or showing signs of resistance may be eliminated from consideration for an award.
- Each entry will exhibit the walk specific to its breed, and its best four beat gait which the breed considers one of its intermediate gaits.
- The best intermediate gait is of the exhibitor's choice, but must be one of the gaits which the breed considers as an intermediate gait (i.e. Paso Fino, Paso Corto or Paso Largo for Paso Fino Horses, Paso Llano or Sobreandando for Peruvian Horses, Show Gait or Pleasure Gait for Mountain Horses). The trot, pace, canter, lope and hand gallop are not permitted.

### Class Procedure

- Horses enter the ring individually. Within 20 feet of entry gate, transition to the intermediate gait, and make one complete circuit of the ring at the intermediate gait.
- Each horse exits the arena before the next horse enters the ring.
- When all exhibitors have completed the circuit, judge(s) will determine which horses continue to the second phase of the competition.
- Horses who met the criteria of the intermediate gait are then called back to the ring for the second phase of the competition.
- The class then proceeds as a normal open gaited breed class.

### To Be Judged:

Each entry will be judged on quality of gait as it conforms to the standard for its breed, and should represent an overall picture of an ideal pleasure gaited horse. Natural animation, if included in the breed's gait standard, is acceptable, but shall not be rewarded over correctness of gait.

- 80% gait
- 20% pleasure horse qualities

### Call of the Class for the Best Gaited Horse Class

- Horses will enter the ring at the walk specific to their breed. The order of gaits called will be breed specific walk, intermediate gait, breed specific walk, reverse, breed specific walk, intermediate gait, breed specific walk and proceed to line-up.
- The judge may call for additional reverses and/or work at the walk or intermediate gait once the required gaits have been performed both ways of the ring.

### OGB 109 Costume Class

- Unless indicated otherwise, costume classes are under saddle.
- The horse and rider may be in costume, the horse only may be in costume, or the rider only may be in costume.
- The costume must be safe for both horse and rider as well as other exhibitors.
- If the horse is saddled the rider must wear boot with a heel.

### To be Judged:

- By judge alone based upon creativity and crowd appeal
- By audience response
- By a combination of judge and audience response.

### OGB 110 DRILL TEAM COMPETITION

**Drill Team Competition is a judged competition where groups of at least 8 horse and rider combinations ride patterns to music. The patterns may be simple or intricate.**

- Drill Team Competition may be divided into categories based upon the age, experience or gender of team members. Competition may be designated Adult, Youth, Open, Novice, Breed of Horse or further limited by gender of either horse or rider.
- Drill Team Competition may be divided into categories based upon style such as Rodeo, Military, Gaited or Historical.
- Competition may comprise Free Drill, **OR** Inspection and Free Drill. The show bill must indicate whether the competition is Free Drill only or a combination of Inspection and Free Drill.
- A team may choose to carry the American flag. If a team chooses to carry the American flag, they must conform to the protocol of respect for the flag. If they fail to follow the protocol (including shafts, be perpendicular to the ground, flying free and not wound around the shaft, to the front or the right of all other flags and riders etc.) they will be penalized.
- A team may choose to carry a Drill Team Flag.
- Drill Team competition may be judged by single or multiple judges.
- A scribe is provided for each judge.
- **Free Drill** - judging based upon performance of the Free Drill only.
- **Inspection and Free Drill** – judging based upon a combination of Inspection and performance of the Free Drill.
- Inspection occurs at a location and time prior to performance of Free Drill.
- The minimum number of horse and riders is 8.
- The maximum number of horses and riders is unlimited.
- Time
  - o If the complete free drill is longer than the maximum of twelve (12) minutes allowed, penalties will be assessed.
  - o If free drill is shorter than nine (9) minutes, penalties will be assessed.
  - o Time begins when the first horse enters the arena and ends when the last horse leaves the arena
  - o Official Timers will be used
- The Order of Go will be determined by lot or by show management
- Drills may include patterns (moves or maneuvers) common to and suitable for drill team competition including but not limited to basic, transition, killer and sneaky.
- A maximum of 7 minutes will be allowed between Drill Team competitions.
- The Drill Team Captain will provide the announcer a prepared script to be read when the team is announced.
- Music
  - o Music is the responsibility of the Drill Team.
  - o Music must be given to show management 24 hours prior to competition.
  - o Music must be in the media (CD or tape) format designated by show management.
  - o Music for the drill must be cued to start at the beginning.

### Prohibited:

- During the Free Drill, no markers will be allowed in or around the arena.
- During the Free Drill, no other person will be allowed to stand or direct in the arena during competition. Only horses and riders in the active drill team are allowed in the arena.

### Penalties:

- Time Infractions:
  - o Over Maximum time – 3 points per minute or fraction of a minute deduction.
  - o Under Minimum time – 3 points per minute or fraction of a minute deduction.

# Chapter 11: Judging Specifics for Open Gaited Breed Division (OGB)

- Fall of Horse and /or Rider
  - o Collision – 15 point deduction
  - o Slip – no deduction
  - o Off Course – deduction at the discretion of the judge

## Definitions

- **Alignment:** Vertical and Horizontal alignment in maneuvers and or transitions
- **Attractiveness:** pattern; symmetry of and definition of maneuvers; method of transition from one maneuver to another.
- **Briskness:** preciseness, alertness and overall attitude of a team in executing patterns.
- **Coordination and timing:** manner in which members work as a team in the performance of patterns and transitions.
- **Degree of Difficulty:**
  - o The difficulty of a maneuver may not be indicative of the spectacular performance of that maneuver.
  - o It is more difficult to perform a maneuver (pattern) well when it is done at a faster tempo.
  - o It is also more difficult to do some simple maneuvers (patterns) well.
  - o Precision will not be sacrificed for speed.
  - o Speed is to be used only as an added point.
- **Horsemanship:**
  - o Rider – equitation position, leads, hands, seat, legs and the use or misuse of cues and aids.
  - o Horse - manners, way of going and suitability as a drill horse.
- **Off Course:** one or more horses out of position during a pattern or transition.
- **Pattern:** Maneuver or move
- **Spacing:** Uniform distance may be varied in succeeding maneuvers (patterns) and or transitions. In line with the requirements of the maneuvers (patterns) and or transitions spacing at any given time should be consistent.
- **Transitions:** actions taken to move from one pattern to another.
- **Variety:** speed, single file, pairs, fours, obloquies, or eights.

## To be Judged (Free Drill Only):

### Entertainment – 30%

- **Costumes - 10 points**
  - o Uniformity and look
- **Choreography : 10 points**
  - o Choice of music
- **Overall entertainment value: 10 points**
  - o Theme
  - o Uniqueness
  - o Audience appeal

### Horsemanship – 20%

- **Rider - 10 points**
  - o Seat
  - o Hands
  - o Control
  - o Attitude
- **Horse - 10 points**
  - o Manners and behavior
  - o Attitude
  - o Suitability as a Drill Team Horse
  - o Way of Going

### Free Drill – 50% - 10 points each

- **Alignment - Spacing**
- **Briskness - Precision**
- **Coordination and Timing - Variety of Patterns**
- **Degree of difficulty**
  - o Speed
  - o Gaits – selection and variety

- **Transition and flow**

## To Be Judged (Inspection and Free Drill):

### Inspection 20%

- **Horse - 6 points**
  - o Cleanliness
  - o Manners
  - o Uniformity of Appearance (color, size, grooming)
- **Tack - 7 points**
  - o Cleanliness
  - o Uniformity
  - o Attractiveness
  - o Adjustments (curb chains etc)
- **Uniform - 7 points**
  - o Cleanliness
  - o Uniformity
  - o Attractiveness

### Free Drill 60% - 10 points each

- **Alignment - Spacing**
- **Briskness - Precision**
- **Coordination and Timing - Variety of Patterns**
- **Degree of difficulty**
  - o Speed
  - o Gaits – selection and variety
- **Transition and flow**
- **Horsemanship**

### Overall Entertainment Value – 20%

#### OGB 111 Racking Style

- Any Gaited Breed is eligible to enter.
- The maximum shoe size will be the lite shod shoe unless Breed Specific Rules allow the one inch shoe.
- Tack and attire is optional, however English and Western may not be combined.
- Breed-specific traditional tack and attire may be used.
- Horses registered in more than one registry may compete with tack and attire appropriate for one breed but not a combination of breeds.
- Ring Protocol and Judging Procedures will be as outlined in the IJA Rule Book.

#### To Be Judged on correct racking form.

#### Call of Class

- Enter at Slow Rack
- Slow Rack, Fast Rack, Walk, reverse, Slow Rack, Fast Rack, Walk and line up.

#### OGB 112 Speed Racking

- Any Gaited Breed is eligible to enter.
- The maximum shoe size will be the lite shod shoe unless Breed Specific Rules allow the one inch shoe.
- Tack and attire is optional, however English and Western may not be combined.
- Breed-specific traditional tack and attire may be used.
- Horses registered in more than one registry may compete with tack and attire appropriate for one breed but not a combination of breeds.
- Ring Protocol and Judging Procedures will be as outlined in the IJA Rule Book.
- Legal leg protection is allowed such as non-weighted bell boots, combi-boots, etc. See 608 for prohibited equipment. All leg protection to be inspected by DQP.

#### To Be Judged on speed while remaining in form.

#### Call of Class

- Enter at Slow Rack
- Slow Rack, Fast Rack, Slow Rack, Reverse, Slow Rack, Fast Rack, Slow Rack and line up.

# Chapter 11: Judging Specifics for Open Gaited Breed Division (OGB)

## OGB 113 Working Trail Pleasure

- A working Trail Pleasure horse is a using horse used for pleasure riding under a variety of conditions and over a variety of terrain.
- The horse is responsive and surefooted.
- The horse is consistent in all gaits.
- The canter or lope is relaxed and ground covering.
- The horse must navigate a minimum of three obstacles. The obstacles count as 25% of the value of the class.
- The working walk **will** be called from any gait. The rider feeds the reins to the horse.
- If **requested** by the judge, the horse must execute a side pass from either side.
- Any Gaited Breed is eligible to enter.
- Horses registered in more than one breed registry may compete with tack and attire appropriate for one breed but not a combination of breeds.
- The maximum shoe size will be as outlined in Chapter 4.
- Ring Protocol and Judging Procedures will be as outlined in the IJA Rule Book.

## Tack and Attire (see 648)

- Trail attire that is clean, neat and safe is permissible.
- Breed-specific traditional tack and attire may be used.
- Any legal tack and attire may be used.
- In all cases tack and attire must match.

## Call of the Class for OGB Trail Pleasure

- Two Gait classes – walk, intermediate gait, walk, reverse, walk, intermediate gait, walk and proceed to the line-up
- Three Gait classes – walk, intermediate gait, walk, canter or lope, reverse, walk, intermediate gait, walk, canter or lope, walk and proceed to the lineup.
- The working walk will be called from any gait.

## OGB 114 “Fun” Classes

### Safety is of prime importance

### Fun is of prime importance.

- Classes are only limited by imagination.
- Classes are affordable and fun
- Attire rules could/should be relaxed.
- Classes could include: flags, keyhole, command or Simon Says, egg and spoon, Delsey Derby, matched pairs, mismatched pairs, apple race, etc.

## OGB 115 Open Gaited Breed In-Hand Obstacle

- Safety of prime importance
- Open or restricted by age of horse and/or exhibitor.
- English or Western or a combination
- Entries shown in halter with a lead shank
- Gloves are **mandatory**.

Class comprises a mandatory section and an optional section. The class must consist of at least 5 obstacles and include 3 of the mandatory obstacles.

### Mandatory obstacles:

- Walk over a minimum of 4 logs in any pattern
- Walk over a bridge or piece of plywood
- Maneuver through cones or poles in any pattern

**The mandatory section is performed twice:** the horse maneuvers the obstacles while being led from the left side and from the right side (off side).

### Optional obstacles or maneuvers may include

- Opening, passing through and closing a gate
- Side pass to either side
- Halt - immobile for 45 seconds
- Back up between rails
- Back through a figure 8

## Judging Criteria

- Each obstacle or maneuver is of equal value
- Tie broken by overall performance

## OGB116 Open Gaited Breed Ground Driving Trail

- This is a standard test – it will be the same at every competition.
- Class limited to 2 and 3 year old horses
- Open to all exhibitors (any age, professional, amateur etc.)
- Entry is **disqualified and all winnings forfeited** if the entry is exhibited under saddle or ridden bareback at any time during the show year.

## Equipment

- This is a working class.
- Equipment must be clean and safe.
- Equipment must meet FOSH standards for humane equipment.
- A horse with a driving harness WILL NOT have an advantage over a horse outfitted with a combination of equipment
- Open Bridle - no blinders or blinkers
- NO overcheck or sidecheck
- Whip permitted - not a lunge whip

## Attire

- Gloves - mandatory.
- Long pants - mandatory
- Shirt - long or short sleeves
- Tennis Boots, riding Boots, or running shoes permitted
- Helmet - mandatory for youth exhibitors.

## Safety Requirements

- Either method **MUST** be used while going through the gate and at all times when entries are in the waiting or holding area.
  - o It is encouraged (but not required) that a “header” lead the entry into and out of the arena.
  - o If a “header” is not used, exhibitor must lead the entry in and out of the arena by the halter/bridle.
- Only 1 entry in the arena at a time.

## Trail Obstacles

- Area must be enclosed.
- Area must be large enough to demonstrate circles of at least 20 meters.
- Enough Poles for a back through “L”.
- 2 Barrels and a sack containing cans (noisy).
- Sheet of plywood or a blue tarp - poles may be added

**To Be Judged** – 100 Points awarded as follows:

### 1. Control – Circle Test- 25 Points

- Drive the horse in a ‘lunge type’ circle in BOTH directions to demonstrate control and easy gait

### 2. Bend and Back - “L” Test - 25 points

- Poles placed in an “L” shape at least 2 feet, but no more than 3 feet apart.
- Walk through the “L” to the end. Back out of the “L” until the horse is outside the poles.

### 3. Can I – Barrel and Noise Test - 25 points

- Drive between 2 barrels.
- Stop with exhibitor even with barrels.
- Pick up the sack and place it on the other barrel. Noise is important.

### 4. Over – Bridge or Water Test - 25 points

- Approach the plywood or the tarp from a distance of 25 feet before the long side.
- Drive the horse over the obstacle.
- Drive the horse at least 25 feet after the obstacle has been crossed.



# Chapter 12: Versatility Class Descriptions and Specifications

## In Hand Division

### V101: Showmanship at Halter (all age groups)

- Classes for showmanship at halter may be offered for all age divisions. Age divisions would include: Adult (18 years & older), Youth (17 & under), Youth (11 & under), and Youth (12-17).
- Showmanship classes are designed to furnish exhibitors an opportunity to demonstrate his ability to fit and show a halter horse. Judging shall be based on exhibitor's ability, and no consideration shall be given to the horse except for grooming and physical condition.
- Horses must be two years-olds or over.
- No stallions are permitted in youth classes.

**Attire** may be English or Western, but not a combination of both, and must be clean and neat. Horses must be shown in an English or Western halter with lead. Lead straps with chains are permitted, but chains are to be doubled through chin ring only. NO chains are allowed under chin of horse or ran up through that halter to the cheek area. Whips are not permitted when showing Western. See 623, 624, 625 and 638.

### Judging Criteria:

#### Appearance of Exhibitor (10 points)

- Suitable English or Western attire, but not a combination.
- Attire and person - neat and clean.

#### Appearance of Horse (40 points)

- Condition (15 points)
- Grooming (15 points)
  - o Hair coat cleaned, well brushed.
  - o Mane and tail tangle-free and clean.
  - o Hooves trimmed or shod properly and clean. May be polished.
  - o Judge may inspect horse by lifting of the mane or tail or looking underneath the horse for cleanliness.

#### Trimming (5 points)

- Inside of ears trimmed neatly.
- Bridle path trimmed.
- Long hair on jaw, legs and pasterns trimmed.

#### Tack (5 points)

- Tack (halter and lead shank) should be neat, clean and in good repair.

#### Showing Horse in Ring (50 points)

##### Leading (15 points)

- Enter the ring beginning to the right and walk on the rail or indicated circle until the judge requests that the horses line up for inspection.
- Walk on left side of horse, holding lead hank neatly and safely. Lead shank is not to be coiled around hand nor should fingers be inserted or laced through the lead. Right hand should be placed at the snap when there is no chain. When a chain is present, lead must be held below chain at the connector. Handler should stay beside the horse, never crossing in front of horse, with exhibitor's shoulder alongside the throat area.
- Animal should lead freely at a walk and middle gait when required.
- After judge has lined up the class, each exhibitor will be requested to MOVE his or her horse individually in the required pattern. Horse should be turned to the right at all times. Exhibitor should be sure that judge has a clear view of the horse at all times. Exhibitor should allow the horse sufficient lead so that the horse can move freely. The ring steward should provide the starting with the judge being the stopping point for the required distance of the pattern.
- Required pattern: exhibitor should turn horse to the right 180 degree turn, stop, lead horse off in a straight line to

the marker, stopping at marker and setting the horse up, at the indication of judge the exhibitor turns the horse over its hocks to the right 180 degree turn moving the horse back to the line up.

- During the line up the judge may request the exhibitor to back the horse. The horse should be backed smoothly, one step at a time, as straight as possible for one body length. Use the press and release technique for backing the horse.
- Do NOT change hands on the lead shank. Touching or kicking of the horse is not permitted.

##### Posing the horse (15 points)

- When posing the horse, the exhibitor should stand at a diagonal facing the horse beside the throat area of the horse with his or her toes pointing toward the horse's eye or head. Never stand directly in front of the horse. Always stay in a position where the exhibitor has view of the judge at all times. The exhibitor should keep good eye contact with the judge.
- The Quarter System is used for judging the horse while in the line up. With the Quarter System, the horse is divided into four sections by drawing imaginary line down his back and another one across his middle. When the judge is looking at the horse's hind quarters, the exhibitor stays on the same side of the horse as the judge, with his or her toes pointed toward the horse's eye or head. When the judge looks at either front quarter of the horse, the exhibitor crosses to the opposite side of the horse.
- Never crowd the other exhibitors. Always leave a horse's length between you and the next horse.

##### Poise, Alertness, and Merits (20 points)

- Keep alert and be aware of the position of the judge at all times.
- Do not be distracted by persons or things outside the ring.

### Quarter System

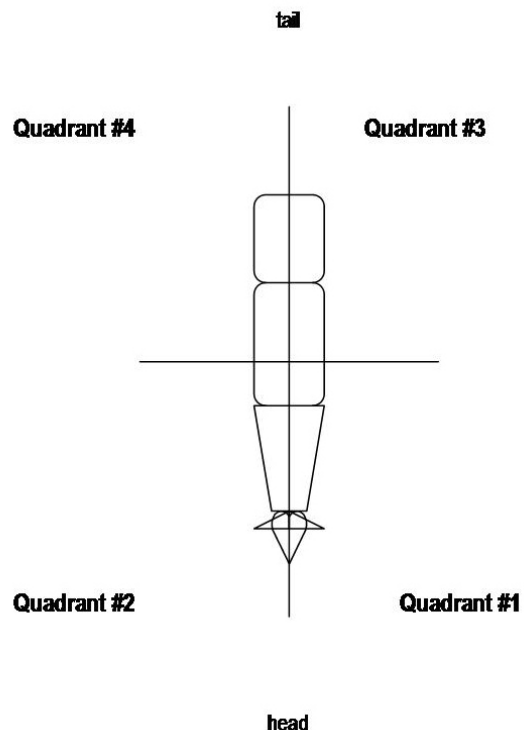

# Chapter 12: Versatility Class Descriptions and Specifications

## Technical I Division

### V102: Barrel Racing

- This is a timed event. The pattern requires a space of approximately 220 feet in length and 145 feet in width. If adequate space is unavailable, the pattern may be reduced in equal increments. Barrels should be placed no closer than 20 feet from a wall, in order to allow room for turning of the barrel. It is paramount to allow adequate stopping room of at least 50 feet behind the “starting line”. The pattern is set in a triangular pattern. Barrels #1 and #2 should be 105 feet apart; Barrel #3 should be 120 feet from barrels #1 and #2. The starting line should be 25 to 30 feet from the first barrel.
- The pattern requires three 55 Gallon barrels, preferably plastic, two starting poles or other type of designation for the starting line. The starting line should be clearly marked with poles, barrels, or a line marked by lime. If poles or barrels are used to designate the start line, they should be at least 20 feet apart and centered on the pattern.
- It is recommended that an electric timer, or two stop watches be used to time the event. In the event stopwatches are used, the average time between the two shall be the official time.
- Upon a signal from the ring steward or timer, contestants begin the pattern with a running start behind the starting line. Timing begins when the horse’s nose crosses the start line and will stop when the horse’s nose passes the finish line, after completion of the pattern.
- The contestant runs to barrel #1, making a right hand turn around the barrel and proceeds to barrel #2. At barrel #2 the rider makes a left hand turn around the barrel, and proceeds to barrel #3. At barrel #3 the rider once again makes a left hand turn around the barrel and then runs for the finish line. The barrel course can be run either to the right or the left. If the pattern is run to the left, the first turn around barrel #1 would be to the left, the 2nd barrel would be turned to the right, and the 3rd barrel would be turned to the right. **See diagram.**
- Knocking over a barrel causes a five second penalty to be added to the finish time. Brushing or touching the barrel by the horse or the rider’s leg, will not carry a time penalty, so long as the barrel does not fall. An exhibitor who breaks the pattern or goes “off course” will receive no time and be disqualified.
- In the event of a tie, a run-off is required.

### Tack and Attire

Western attire and equipment is required. **Helmets are required on all riders.** See 645 Western Tack, Equipment and Attire for appropriate attire and equipment. Skid boots, polo wraps, splint boots, combi boots, nonweighted bell boots, tie downs and standing or running martingales are permitted. See 608 for Prohibited Tack, Equipment and Attire.

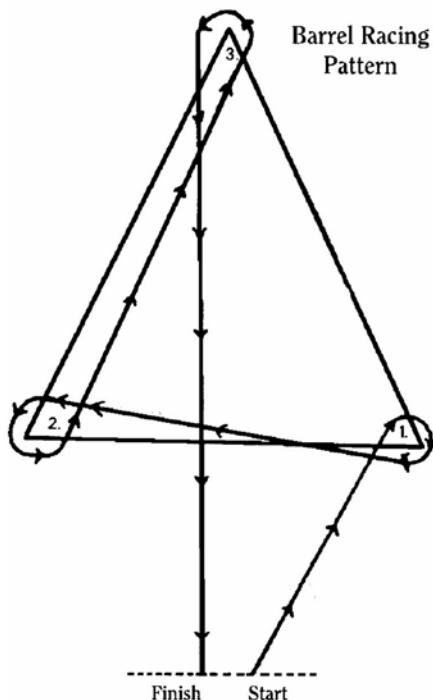

### V103: Equitation

#### General Information

See 620 Equitation and 608 Prohibited Tack, Equipment & Attire. Equitation classes may be designated for a specific style of riding (Saddle Seat, Walking Seat, Hunt Seat, Dressage Seat or Stock Seat). In addition Equitation may be designated as Open when the class comprises a variety of styles of riding including traditional styles or a specific gaited breed. In all cases, Equitation is the art of horsemanship. To matter the style of riding, the rider must demonstrate the ability to influence the horse to perform properly and to smoothly execute gaits and commands. In addition the rider must demonstrate an effective and correct seat.

- The physical impairment of a horse such as blindness in one eye, a nerved horse or similar conditions shall not count against the equitation rider unless the impairment of the horse is sufficient to affect the ability of the judge to evaluate the rider’s performance or the condition causes the horse observable distress while under saddle. Unsoundness of the type that constitutes bad image requires immediate elimination from the class.
- The performance of the rider is paramount in equitation classes. The horse is to be considered as a factor only when its performance reflects a lack of ability or control on the part of the rider.
- Show management may divide equitation classes into sections based on age, youth and adult status, open and amateur status, styles of riding, specific gaited breed and other breakdowns as appropriate.
- A fall from the horse by the rider or a fall by the horse will result in disqualification. No attendant will be allowed in the ring with an equitation rider except at the request of the judge.
- Equitation classes may be either two or three gait. When a three-gait class is in session, the judge may request an extended canter or the hand gallop. The canter may be requested from the walk, the rein back or a halt.
- In Grand Championship classes a counter canter may be called at the judges’ discretion.
- Both horse and rider must be groomed to an exceptional standard in equitation classes.
- **Gloves are mandatory** in all equitation competition.
- Only unrowelled spurs may be worn.
- Judges must excuse riders who do not conform to the proper appointments required in this division or who present themselves or their mount in an unclean, untidy, or disheveled manner.

**Individual Tests.** Judges may require that tests or patterns be ridden in equitation classes. A test or pattern must be posted a minimum of one hour before the class and the decision to require a pattern must be announced.

The following elements, in any combination, may be required:

- back the horse and address the reins (Saddle Seat);
- back the horse and do execute a 360 degree turn, (on the haunches not required);
- a circle at the trail walk;
- a figure eight at the show walk;
- a canter or lope down the centerline with a stop at the midpoint of the arena;
- a three loop serpentine ridden at the show walk;
- a figure eight at the canter or lope with a simple change of lead at the midpoint;
- a figure eight at the canter or lope demonstrating a flying lead change at the midpoint;
- a turn on the forehand;
- leg yielding from the rail

## Chapter 12: Versatility Class Descriptions and Specifications

### Saddle Seat/Walking Seat Equitation

**Saddle Seat/Walking Seat Basic Position:** The following elements are required in saddle seat equitation:

- Head high and looking forward
- Shoulders even and square with the ribcage drawn up and out of the belt area
- Waist supple but not collapsed; back supple neither collapsed nor rigid
- Buttocks neatly tucked and seated on seat bones not rolled forward on the crotch
- Deep seat, close and in contact with the horse, “perching” to be penalized
- Thighs and knees in close contact with no gripping of the lower leg but contact that might be described as draped like a wet towel. Toes to be pointed forward with a supple ankle and heels carried down. Riding with “feet on the dashboard” or legs held straight out away from the horse will be penalized.
- The irons should touch the rider just below the ankle when the foot is removed from the stirrup.
- Forearms should be parallel to the ground. A slight angle when seen from above is acceptable. Wrists must be supple.
- Hands and forearms should form a V when viewed from above. Hands should be held over the withers, far enough apart that the thumbs almost touch when extended. Hands that are turned flat, in the position that would be seen while playing the piano, are to be penalized. The touch of the rider’s hands on the reins should be light, yet clearly in contact.
- The reins should be held between the thumb and index finger with the remainder of the fingers closing gently but firmly around the reins. The rider may also elect to run the bottom of the rein above the little finger before closing the hand. The bight of the rein shall fall to the right side. The hands may not cross the neck while the horse is motion and riders will be penalized for this error.
- An imaginary vertical line, drawn on the rider from a side view, would show a straight connection from the ear through the shoulder to the elbow, traveling down the body through the hip to the heel.

**Saddle Seat/Walking Seat Position in Motion.** The start into forward motion should be smooth and gradual with the employment of necessary leg and seat aids and a slight release of rein pressure. At all gaits an even tempo must be maintained. The rider must be supple, alert, and capable of maintaining the horse at gait, with invisible aids, on the straightaway and through the corners. If required, the canter is executed from the trail walk. The inside leg is to remain on the girth and the outside leg should be positioned slightly behind it. Thumping or kicking of the horse will be penalized. The horse must be well collected with the rider’s hands quiet and the body following the movement of the gait.

- o All transitions must be gradual with no abruptness.
- o At the halt the rider’s weight shall be well down in the saddle, rein pressure shall be even.

Reverses are ridden toward the rail.

### Stock Seat Equitation

**General.** The general guidelines for equitation, including the section on tests, apply to stock seat equitation.

#### Stock Seat Basic Position.

- The body must be upright, comfortable, relaxed and flexible in appearance. The appearance of rigidity will be penalized.
- The foot must rest in the stirrup with the weight on the ball of the foot.
- The free arm may be held across the chest with the hand clenched or allowed to hang loosely in the vicinity of the thigh.
- Either split reins or romal reins may be used.

- o When using split reins the hand may be around the reins OR one finger may be inserted between the reins. When the hand is around the rein, the rider may hold the end of the reins with the opposite hand to keep the reins from swinging. When one finger is inserted between the reins, the ends of the rein must fall on the side of the reining hand and the reins must not be held to keep from swinging.
- o When using romal reins the hand must be around the reins in an upright position. The rider may hold the end of the reins to keep them from swinging but the romal must be held at least 16 inches away from the reining hand.
- The rider must sit in the middle of the horse, with quiet hands and in correct position.
- The legs must remain steady with heels lower than toes and weight evenly distributed across the horse’s back.
- Noticeable shifting of the rider’s weight to influence movements is not desirable.

### V104: Water Glass

- This class may be ridden in English or Western tack and attire.
- Each exhibitor enters the ring and receives a glass to be filled with water.
- One hand only is to be used in holding the glass. The hand may not cover the top of the glass, and the glass should be held as if the rider were drinking out of it. The glass should be held out and away from the body of the horse and rider.
- Once the glasses are filled, the exhibitors are put on the rail and perform the flat walk and intermediate or middle gait both ways of the ring. A noticeable change in speed between the flat walk and the intermediate or middle gait is mandatory. **The horse must be excused if a distinct change in speed is not performed.**
- Upon completion of the gaits, exhibitors are brought to center ring.
- The exhibitor with the most water remaining in his/her glass wins the class.
- In case of tie, a canter may be called.
- See **645** Western Tack, Equipment and Attire and **638** Saddle Seat Tack, Equipment and Attire, **606** Other Acceptable Tack Options and **608** for Prohibited Tack, Attire and Equipment.

### V105: Pole Bending

- This is a timed event.
- This pattern requires approximately 150 feet in depth. Six Poles (preferably plastic or PVC) of at least 6 feet in height are placed in bases, heavy enough to keep the poles from leaning or falling, but not more than 14 inches in diameter. The upright poles are placed 21 feet apart in a straight line. The farthest pole from the starting line should be at least 20 feet from the end wall or fence to allow adequate turning room. The first pole should be placed 21 feet from the starting line.
- The starting line should be clearly marked with poles, barrels, or a line marked by lime. If poles or barrels are used to designate the start line, they should be at least 20 feet apart and centered on the pattern. Timing begins when the horse’s nose crosses the start line and will stop when the horse’s nose passes the finish line, after completion of the pattern.
- It is recommended that an electric timer, or two stop watches be used to time the event. In the event stopwatches are used, the average time between the two shall be the official time.
- **This pattern can be run either to the right or the left.** Upon a signal from the ring steward or timer, contestants begin the pattern by running straight down one side of the line of upright poles. Upon reaching the far end pole, the rider makes a turn around the pole and serpentine back through the remaining five poles to the end pole nearest the starting

## Chapter 12: Versatility Class Descriptions and Specifications

line. Upon reaching the end pole nearest the starting line, the rider turns around the pole and serpentines back up through the poles to the far end pole and turns around it, at which point the rider runs for the finish line. **See diagram below**

- Knocking over a pole or holding onto a pole with a hand (in an attempt to stop the pole from falling) will cause a five second penalty to be added to the finish time. An exhibitor may rub or come in contact with the pole with his or her arm or leg, without penalty. The horse may touch the pole without penalty, so long as the pole remains standing. An exhibitor who breaks the pattern or goes "off course" will receive no time and be disqualified.
- In the event of a tie, a run-off is required

### Tack and Attire

Western attire and equipment is required. **Helmets are required on all riders.** See **654** Western Tack, Equipment and Attire. Skid boots, polo wraps, splint boots, Combi boots, non weighted bell boots, running or standing martingales and tiedowns are permitted. See **608** for Prohibited Tack, Attire and Equipment.

### Pole Bending Pattern

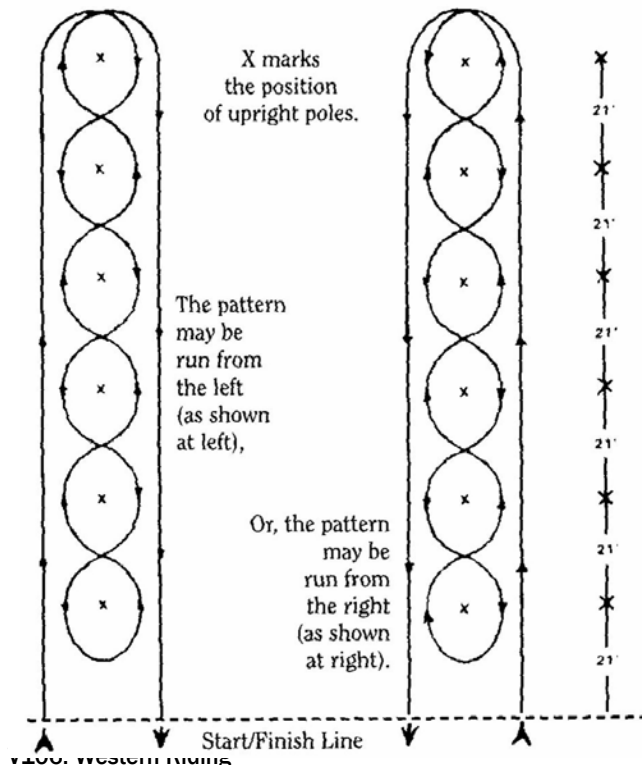

Western Riding is a "set pattern" class to be ridden in Western attire. See **645** Western Tack, Equipment and Attire and **608** Prohibited Tack, Equipment and Attire

Western Riding rewards the horse with the athletic ability to do a variety of tasks on the farm or ranch. The performance is to be judged on riding qualities of the gaits to include the walk, intermediate or middle gait and lope; change of leads (flying); back up, responsiveness to rider; manners and disposition. Penalty will be affixed for simple change of leads and not performing gaits as specified in the pattern.

### Pattern:

- The eight small circles represent markers (cones recommended). The cones should be separated by a uniform distance of not less than 30, nor more than 50 feet.
- The rectangle represents an obstacle (one small log recommended)

ended) just high enough to break the animal's stride.

- The long and sometimes twisting line indicates the direction to travel and gaits at which the animal is to move. The dotted line (....) indicates the walk, the dash line (— —) the running walk, and the solid line (——) the lope.
- Proceed with the routine as indicated by the pattern. On completion, exhibitor rides to the center of the pattern and backs the animal as indicated by the pattern.
- The judge may require an exhibitor to repeat or reverse any part of the routine.
- Only one hand may be used on the reins and must not be changed.
- The hand is to be around the reins. One finger between the reins is permitted when split reins are used. While the animal is in motion, the rider's hands must be clear of the horse and saddle.

### Disqualifications:

- Off course on the pattern.
- Using spurs or rein ends forward of the cinch.
- Unsoundness as determined by the judge.
- Equipment failing in ring as to make an unsafe condition.
- Fall by either horse or rider

### Tack and Attire

- Non-weighted bell boots, Polo Wraps, Splint Boots, Combi Boots and skid boots are permitted.

### WESTERN RIDING PATTERN

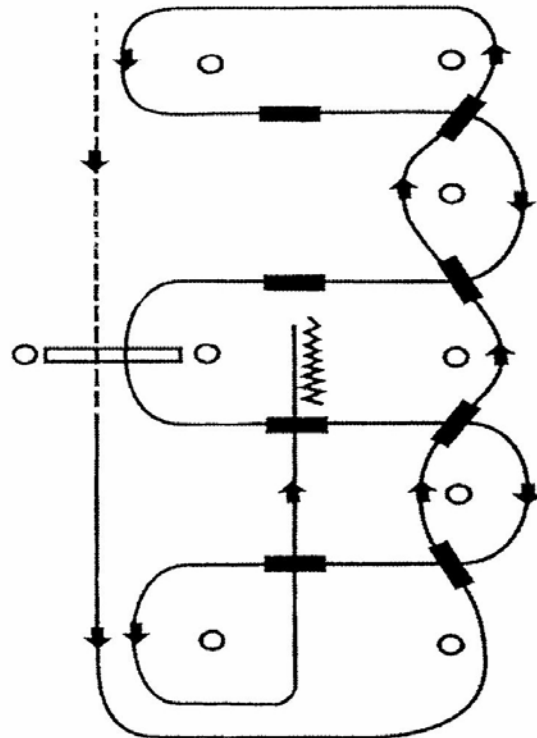

# Chapter 12: Versatility Class Descriptions and Specifications

## V107 EquiTheater

### Description:

- EquiTheater is where each exhibitor creates and presents with their horse, an entertaining routine to the audience using: costumes, choreography, music, props, storytelling and acting. Routines may be serious, dramatic, elegant or funny.
- EquiTheater is not like any other musical horse sport, because it has fewer required elements, and the main emphasis of a routine is on its ENTERTAINMENT value, not on how well a horse performs.
- EquiTheater is not a Dressage Kur or a Freestyle Reining pattern. It is not stepping, prancing or dancing around in the arena, nor riding on the rail in a costume with background music. It is not a horse(s) at liberty act, nor a trick horse(s) act.
- The primary emphasis is to encourage exhibitors of all ages and all abilities and their horse(s) to have FUN with EquiTheater, and for EquiTheater to attract spectators.
- All exhibitors should understand that judging is very subjective.
- Although special tack or attire is not required, exhibitors must still adhere to the IJA rules for shoeing, shank length on bits and comply with all other IJA rules that promote the humane treatment of the horse (restrictions on action devices, severe bits, etc.)
- Costuming, song and routine must all be “G” rated, suitable for a general, family oriented audience. For example nothing risqué, controversial, demeaning, derogatory, or using bad language is allowed. Use of the National flag is not allowed.
- Show management may reserve the right to not accept an EquiTheater presentation that they do not consider suitable for any reason.
- Although costumes are an integral part of this class, safety for both horse and rider is of prime importance.
- For safety purposes, a “spotter” is allowed in the arena for beginning, young, fearful or handicapped exhibitors etc.
- A solo routine is one horse/one exhibitor; a duo routine is two horses/ two exhibitors; and a trio routine is three horses/three exhibitors. Horses may be ridden, driven, in-hand (In-hand includes line driving), or any combination thereof. Each entry may use “extras” (people) to come and go, or to stay in the arena to serve as props, characters, or actors in the skit.

### Required Elements:

- While there are no time limits, guidelines are: each routine to be a maximum of 4 minutes; an additional 2 minutes in total is allowed for setting and dismantling props.
- The arena is considered is a stage and exhibitors should position their routine so they perform to the audience. The performance should have a balanced appearance.
- Riding in figure 8 type patterns, or riding exclusively on the rail will be penalized.
- The performance must include at least one stop and one back-up.
- The exhibitor must demonstrate at least 2 gaits, each gait in both directions of the ring.
- In addition to the other required elements, in-hand exhibitors must work off both sides of the horse. (In-Hand classes include Line Driving.)
- **To ensure performance is suitable, a written description of the presentation and music must be submitted with Entry fees.**

### When the numbers of Entries Warrant, Classes may be offered for:

- Any gaited breed either ridden, driven or In-Hand, or any combination there of. In-Hand classes include Line Driving
- Any age exhibitor
- Any age horse
- 2 or 3 gaits

### Judging Criteria:

- EquiTheater is judged by individual evaluation.
- The judge **must** sit in the audience for judging and **must** use the scoring sheet.
- Scoring criteria: **60% entertainment 40% required elements.**

### Technical II Division

#### V108: Dressage

**IJA Dressage for Gaited Horses allows the use of non-traditional tack and attire – show management may allow Dressage competition in alternate tack and attire (Western, traditional breed, saddle seat, etc), but the bit must be a snaffle and spurs must be blunt.**

**Full information of Dressage for Gaited Horses can be found in The IJA Manual for Gaited Dressage on the FOSH website.**

- The purpose of the Dressage division is to demonstrate that the horse has been systematically trained to be responsive to the aids, accepting of the bit, is forward moving and supple, is capable of clean transitions, is not resistant, and is able to execute with precision a series of gymnastic exercises at prescribed locations as required by the test. Continuity of movement, freedom, consistency of tempo and well being of the horse are paramount.
- The primary purpose of the dressage test at a FOSH sanctioned show is to measure the training of the horse and to indicate areas where improvement can be made or increased attention is required.
- The placing of the horse is secondary to the education opportunity that the ride should provide. The scores should reflect the quality of training based upon the following principles as it pertains to the level under which the horse and rider are competing: Quality of Rhythm; Degree of Suppleness; Acceptance of Contact; Elasticity of Impulsion; Degree of Straightness, Quality of Collection
- Dressage tests will be scored as per the written requirements for each test. (See Appendix 7).
- The tests are designed to develop progressively with the horses training. The purpose of each test is printed on each test and the scores should reflect the ability of the horse and rider as it pertains to the **level** at which they are performing.
- The score for each movement should first establish whether the movement is performed insufficiently (4 or below) or sufficiently (5 or higher).
- Each movement on the dressage test will be given a score of 1-10.

10	Excellent	Couldn't be much better
9	Very good	Better than expected at this level
8	Good	A good representation of the requirements
7	Fairly good	Meets the requirements fairly well
6	Satisfactory	Meets the requirements
5	Sufficient	Just meets the requirements
4	Insufficient	Does not quite meet the requirement of the movement
3	Fairly bad	Misbehavior or misunderstanding of requirements
2	Bad	Still on pattern, but movement difficult to determine
1	Very bad	Difficult to determine where or what has happened
0	Not executed	Nothing of the required movement has been performed

- The intermediate gait shall be considered that which comfortably falls between the medium walk and canter for each individual horse and rider. The intermediate gait shall be

## Chapter 12: Versatility Class Descriptions and Specifications

considered the working gait for each breed. It must show engagement and impulsion (desire to move forward)

- Given the variations of the Intermediate gait, and the coefficients assigned, the Collectives at the bottom of the test become particularly important. The evaluation of the Gaits should include the concepts of regularity of rhythm, consistency of tempo (speed), and balance. Impulsion should include the desire of the horse to move forward in an elastic, relaxed manner. Submission should include the ability of the horse to accept the contact and guidance of the aides with ease. And the Rider score should reflect the position of the rider and their ability to positively influence and direct their horse.
- The walk in dressage tests should be a true working walk.

### Procedure:

- Competitions may take place in either the small arena (20 meters X 40 meters) or the standard arena (20 meters X 60 meters). A meter equals 3.281 feet. The judge will be seated 5 meters away from the letter "C".
- A number must be on the back of each rider unless show management provides Dressage numbers
- When Dressage numbers are supplied, the number must be exhibited on the headstall, pinned to the saddle pad, or attached to the top of the boot on the near side of the horse.
- Memorization of the test is not required for competition. Riders who have not memorized the test must provide their own readers.
- Riders must enter the arena at their ride time. The judge will ring the bell or blow the whistle to let the rider know that it is time for competition. The rider has one minute after the bell or whistle to enter the competition arena
- The ringing of a bell or the blowing of a whistle by the judge during a test, will signal to the exhibitor and error has been made. The rider will then come to the judge for instruction and then proceed with the remainder of the test. Such errors receive penalty points in the final scoring.
- A horse that steps outside the arena during a test must be eliminated from competition for awards: but they may reenter the arena and complete the test. A score will be given for educational purposes only.
- Judges may, if time allows, call exhibitors to the judge's stand after the ride for a quick critique of the ride.

**Tack and Attire:** For full description refer to **618** Dressage and **608** Prohibited Tack, Equipment and Attire

### Judging Terms for IJA Dressage Tests

#### Movement

- The manner in which the horse moves over the ground Working Walk
- The horse moves in an energetic but calm way, with stride length between collected and medium movement.

#### Medium Walk

- The frame and stride of the horse is lengthened and the neck oscillates

#### Free Walk

- The horse is allowed complete freedom to lower and stretch their head and neck.
- The horses' stride and frame are lengthened.
- If the movement is on a long rein, some contact is maintained.
- If the movement is on a loose rein, there is a loop in the rein and there is no contact.

**\*Collected Movement** (may or may not be included in future IJA Dressage Tests)

- A movement where the horse is "gathered together". The strides are shorter (yet powerful) and the legs are more elevated. The outline of the horse appears shorter from bit

to hip and the neck rises and stretches unrestrained out of lifted withers.

- Movement at the walk shows elevation of the horse's carriage with the neck stretched upward and forward, and a shortened stride.
- At the canter the horse shows a more uphill balance with greater impulsion. At no time should the head be beyond the vertical.

**\*Extended Movement** (may or may not be included in future IJA Dressage Tests)

- Stretching and lengthening of the outline and stride of the horse
- An increased phase of suspension at the canter.
- The horse covers as much ground as possible with each stride, but maintains nearly the same tempo.

### Test Movement

- A section of a dressage test to be evaluated with one score on a score sheet.

### Dressage Movement

- An exercise rather than a figure, pattern, transition, or combination of those. Traditional Dressage movements include : leg yielding, rein-back, shoulder-in, travers, renvers, half-pass, flying changes, pirouettes, turn-on-the haunches, piaffe, passage.

### Requirements for Competition Managers for Dressage classes

- A qualified judge must be provided and copies of the tests must be provided to the judge 30 days before the event. (See Appendix 7 for tests.).
- A scribe must be provided for each judge.
- Adequate shelter for the judge as well as a table and chairs, a bell, whistle, tests, pens and water.
- A properly sized competition arena must be set up, with letters in place, and a 15 foot apron around the arena where competitors may warm up prior to riding the test.
- Comments and scores must be in pen.
- Dressage tests are not for public display. Scores are posted, not tests.
- Each exhibitor is to receive a copy of the test score sheet at the conclusion of the event.
- Dressage tests are located in Appendix 7.

### V109: Pleasure Driving

- Pleasure driving is to be judged on the pleasure horse qualities of the horse in harness.
- The gait is to be of the using variety rather than the highly animated. Animated entries should be placed in fine harness competition.
- The walk and an intermediate gait is required both ways of the ring.
- Horses must be able to back in the shafts.
- Any signs of unruly behavior or resistant behavior or any conduct that disrupts the class or puts other driving entries at risk will result in elimination from the class.
- Youth drivers may be accompanied by an adult as a safety precaution. However, should the adult touch the lines during a class, the entry will be eliminated from consideration.

### Appointments

- Fine harness buggies or viceroys are not permissible in pleasure driving classes.
- Breeching is required with wooden wheeled vehicles but not with wire wheeled vehicles.
- Any serviceable two-wheel cart or four wheel buggy is acceptable but two and four wheel vehicles should not be shown in the same class.
- Overchecks, snaffles or Liverpool bits are permissible. Flash nosebands are permissible only with snaffle bits.
- Blinkers or blinders are required.

## Chapter 12: Versatility Class Descriptions and Specifications

- A whip not to exceed 6 feet in length is permissible.

### Attire:

- **Gloves for whips (drivers) are mandatory.** Lap robes are optional.
- Gentlemen drivers may be attired in traditional saddle seat attire or in business attire to include a coat, tie, slacks, and hat.
- Lady drivers may be attired in conservative dress, blouse and skirt, shirt and jods with apron, saddle suit or day coat and jods. Hats are optional for women but are encouraged.

### Class Routine

Driving horses are to enter the ring to at a walk and perform the trot or intermediate gait when the second gait is called for. The reverse is to be executed on the diagonal at a walk, at the direction of the ring steward or announcer. One header is permitted in the line-up but touching the horse results in a penalty. Horses must stand quietly and back readily. Driving classes are to be judged: 70% on manners, performance, condition, style and way of going; 20% on fit, condition and appropriateness of harness and vehicle; 10% on conformation and neatness of driver.

### Faults in Pleasure Driving

- Rearing in the shafts is cause for elimination.
- Deviation from the correct intermediate gait and breaking into the canter from any gait.
- Erratic movement, hesitation in going forward, inconsistency in the gaits
- Unsafe behavior (mandatory dismissal)
- Resistance to the lines, throwing of the head or gaping of the mouth
- Balking or refusing to go forward or to turn

### General Rules for Driving

- Only the driver is permitted in the vehicle, with the exception of the youth provision
- Large classes may be divided at the discretion of the judge if he feels that the space in the ring is inadequate for the numbers of vehicles in competition. Judges may select drivers from each section and combine them into a final workout in order to tie the class.
- Doctor's buggies, surreys, and other period vehicles are considered inappropriate for pleasure driving unless the class is designated as an **antebellum class** or a **period costume and vehicle class**. In the event of a period driving class, judging is based 50 % on performance, 15 % on the outfitting of the whip and other riders, 25% on the vehicle and harness and 10 % on the overall turnout.
- If **obstacle driving** is offered, courses may be judged on either faults or faults and time. The decision must be posted in the office at least two hours before the class is to be held. Over or side checks and running martingales are prohibited in obstacle driving classes.

### V110: Freestyle Reining

Reining maneuvers originate from moves that a cow horse must use in performing its duties and have been refined to the high level of competition that exists today. Freestyle Reining not only provides an opportunity to use these maneuvers creatively, but also to expand them to music by means of choreography. Exhibitors are encouraged to use musical scores which permit them to show the athletic ability of the horse in a crowd appealing way. Musical selections are chosen by the exhibitor and may be combined and edited to fit the Freestyle pattern and time requirements.

- **Time Limit** Maximum of 4 minutes including any introductions. The time limit will be from the beginning of the music or from the beginning of the introduction (whichever is first) and will end with the music. Failure to perform all the required

maneuvers or failure to complete the performance within the time limit will result in a score of 0.

- **Required maneuvers** will be defined as follows:
  - o A minimum of 4 consecutive spins to the right.
  - o A minimum of 4 consecutive spins to the left.
  - o A minimum of 3 stops.
  - o A minimum of 1 lead change at the canter from right to left.
  - o A minimum of 1 lead change at the canter from left to right.
- Additional repetitions of required maneuvers are appropriate, but will only add or subtract from the existing scores already given for the required maneuvers, not as additional scores. Additional maneuvers such as rollbacks, backups, speed variations and non classical reining maneuvers such as half pass and side pass are appropriate in Freestyle and shall be given appropriate credit.
- Validating required maneuvers will not be the responsibility of the judges. At least one scribe will be used to verify the required maneuvers for each horse as they are completed in the pattern.
- Exhibitors will only be judged astride.
- Exhibitors are allowed to use two hands (as well as one or no hands) and any bit approved herein, including snaffle bits and bosals approved for use in the Snaffle Bit or Hackamore classes.
- **Costumes:** Permitted but not required. Emphasis is placed on performing the reining maneuvers to music. Props are permitted but at no time may they hinder the judges' view of the horse. The use of props will not add to the score.
- Show Management will reserve the right to rule on music or dress that may be inappropriate or offensive to the spirit and nature of the show. Show management may also determine the use of special lighting.
- **Judging** of Freestyle Reining: Each exhibitor will be judged 0 to infinity, with 70 denoting an average performance.
- Scores will be weighted according to the following formula: Technical merit = 75%, artistic impression = 20% and applause meter = 5%.
- Ties for first place will be run-off.
- Only one horse allowed in the arena during each presentation. Props may not include open flame or live animals.
- **Freestyle Reining is open to horses of any age that are eligible to show in FOSH sanctioned shows.**

### Tack and Attire

Freestyle Reining is a western class and western tack and equipment are required. Polo wraps, splint boots, skid boots, combi boots and non weighted bell boots are permitted

### V111: Over Fences and Jumping

- Fences should simulate obstacles found in the hunting field (poles, rails, brush, wall, gates and coops, etc.) and have the appearance of being solid.
- Jumper fences such as "bulls-eyes", stripes and spreads of over four feet are prohibited.
- A ground line (pole) is recommended for all fences. (A pole as long as the jump, laid on the ground just below the jump or approximately 18 inches from the base on the approach side).
- Post and rail fences must have a minimum of two rails per fence, excluding ground line. The maximum space between rails should not be more than 12 inches.
- A combination fence such as an "in and out" may be used. They count as one fence. Both "a" and "b" should be the same height and twentyfour to twenty-six feet is a suggested distance between them, when used in a ring.

## Chapter 12: Versatility Class Descriptions and Specifications

- Wings may be used and if so must be thirty inches wide and twelve inches higher than the top of the fence
- A simple fence such as post and rail should be used for the first obstacle on any course.
- When setting up the distance between single fences, the rule of thumb to use is distance divided by increments of 12 (24, 36, 48 feet, etc).
- A course should have two directions with one change of lead. Jumps may range from a minimum of two feet to a maximum of three feet. A fence must be at least 12 feet wide or have wings at least 30 inches wide that are 12 inches higher than the fence (pen jumps excluded).
- A course consists of eight jumps, of at least four different obstacles. An obstacle may be jumped more than once.
- Exhibitors should have the opportunity to walk the course without their horse to check striding, etc. prior to commencement of the class. A warm-up of two or more fences must be available. The course does not have to be in the ring, but may be setup to the side of the ring, etc, becoming an outside course.
- A full circle before starting the course is customary and sets the hunter pace which is carried throughout the course. A circle may be made at the finish
- Way of going of a consistent, even, safe hunter pace, manners and soundness are to be emphasized. Hunter pace is defined as a longer, flowing canter with enough speed and impulsion to meet and take each jump giving the appearance of grace and ease. It should be maintained throughout the course, including the beginning and the ending circle.
- The idea hunter will meet each fence at the proper take off spot for a perfect arc over the obstacle. Its jump will be snappy and athletic with the forearms held at or above a parallel line to the ground. The joints of the front legs are tucked tightly in front of the chest, and the neck and back arched over the fence.

**Faults:** knock-downs, extra circle and refusals.

### Elimination:

- third refusal on a jump,
- off course,
- fall of horse and/or rider,
- jumping out of order,
- jumping before the jump or jumps are re-set

**Further penalties:** Excessive speed and breaking gait between jumps

### Tack, Equipment and Attire

For complete description see **631** Over Fences and Jumping and **608** Prohibited tack, Equipment and Attire. Tie downs, Running or standing Martingales, Polo wraps, splint boots, combi boots and non weighted bell boots are permitted.

### V112: Natural Horsemanship

#### Overview

- Over 2,000 years ago, one of the first great riding masters was a man named Xenophon. He said that communication is the key to horsemanship. Learning to communicate with your horse is vital if the two of you are to be on the same track as partners. The dynamics relating to modern natural horsemanship can be obtained through communication, understanding, and psychology.
- The goal of FOSH is to provide a forum for the horse and rider who have achieved a level of communication and understanding, using Natural Horsemanship skills. This forum may be established in local class lists and may be offered at the North American Championship.
- A horse and rider team will work in unison in the arena, us-

ing ground obstacles, obstacles while riding and riding skills as they exhibit their level of communication. Only one horse and rider team will be allowed in the arena during exhibition. Stallions are permitted but the horse and rider team **MUST** be the only exhibitors in the arena during their session.

**Prohibited equipment** See also **608** Prohibited Tack, Equipment and Attire. No spurs, bits, bridles, stiff bosals or mechanical hackamores, whips

### Allowable equipment

Horses **must** be ridden in a rope halter with one or two reins, or with a soft rope around the neck. Clips with metal may be used to attach reins or ropes to halter. Saddles are optional and may be English, Western, Buena Vista, or Australian either with or without a horn. Bareback pads may be used. **ATSM Helmets are mandatory** in ALL natural horsemanship classes. Judges are required to excuse any rider in a Natural Horsemanship class that appears without a helmet.

### Class Criteria

**Patterns including obstacles must be provided & posted in advance by show management.**

- All obstacles must be negotiated on line (lead) or at liberty on the ground. The only physical contact allowable between the horse and rider while on the ground shall be through the line (lead). Ground skills and communication between horse and rider are paramount. The horse shall be sent over an obstacle or maneuver an obstacle with ease and an appearance of harmony with its handler. Hand or body contact while maneuvering ground obstacles will be penalized in the final scoring.
- After the ground obstacle portion has been completed, the rider is asked to mount his horse (a mounting block may be used). The horse must stand ready and be alert to his rider cues. A repeat of the "on line" obstacles and /or predetermined patterns may be call for at this time. The class may call for a variety of gait changes, i.e., working walk, flat walk, running walk, and, in the advanced division the lope or canter. The purpose of the gait changes would be to observe a harmonious response to the rider and to consider how well the horse maintains the gait on a loose rein. The judge will reward the horse and rider that exhibit harmony while riding.

### Judging Criteria

Scoring will be based on ground manners and maneuverability of obstacles, unison between horse and rider while riding through obstacles and /or patterns, and overall harmony and partnership between the horse and rider. Currently there are two levels of competition defined for the horse and rider team:

**1) Beginning Natural Horsemanship** – This class should use several ground obstacles, several riding obstacles and call for a simple pattern to exhibit the beginning stages of partnership between horse and rider.

**2) Advanced Natural Horsemanship** - This class should challenge the horse and rider through a series of ground obstacles, riding obstacles and a more complex pattern to exhibit the ultimate partnership between horse and rider. The advanced Natural Horsemanship class may ask for the lope or canter.

### V113: Reining

- The reining pattern to be used must be posted at least one hour prior to the class.
- The pattern is worked individually. Horses shall enter the ring one a time at the call of the announcer or numerically from the class sheet. The exhibitor shall proceed to the judge for direction to start the pattern.
- Show management will choose one of six basic reining pat-



## Chapter 12: Versatility Class Descriptions and Specifications

terns. Refer to **Chapter 6** for appropriate Western attire and equipment. The use of skid boots, polo wraps and split boots are allowed.

### Scoring

- Scoring will be on the basis of 60 to 80, with 70 denoting an average performance.
- Each entry will be judged on the neatness, dispatch ease, calmness and speed with which it performs the pattern.

### Disqualifications

- Going off course or breaking the pattern.
- The fall of horse or rider
- Excessive spurring

### Faults against the horse which do not cause disqualification:

- Opening mouth excessively (when wearing the bit)
- Excessive jawing, opening the mouth or raising the head upon the stop
- Breaking gaits
- Lack of smooth, straight stop on the haunch
- Refusing to change leads at the appropriate time
- Anticipating signals from rider
- Stumbling
- Wringing of the tail
- Backing sideways
- Knocking over markers

### Faults against the rider, but which do not cause disqualification:

- Changing hands on the reins
- Two hands on the reins (except for junior horse in a snaffle)
- Losing a stirrup or holding on
- Any unnecessary aid or discipline given by the rider, such as unnecessary talking, petting, spurring or jerking of the reins.

### Tack, Equipment and Attire

Western tack, equipment and attire are required. Polo Wraps, Skid boots, Splint boots, combi Boots and non weighted bell boots are permitted. See **645** Western Tack, Equipment and Attire. See **608** for Prohibited Tack, Equipment and Attire.

**Reining Patterns 1 through 6 follow.**

## Chapter 12: Versatility Class Descriptions and Specifications

### Reining Pattern 1:

End markers should be placed at least 75' from the center marker. Pattern area should be approximately 50' x 150' in size.

1. Run to the far end of the arena, stop and do 2 ½ spins to the left, no hesitation.
2. Run to the opposite end of the arena, stop and do 2 ½ spins to the right, no hesitation.
3. Run past center of center, do sliding stop, no hesitation; back over slide tracks to center, hesitate.
4. Make a 1/4 pivot to the left to face left wall, hesitate.
5. Begin on right lead and make two circles to the right, the first small and slow, the second large and fast. Change leads at center of arena.
6. Make two circles to the left, the first small and slow, the second large and fast. Change leads at center of arena.
7. Begin a large fast circle to the right, do not close this circle but run straight down side past the center, do sliding stop. (Stop at least 20 feet from wall or fence.)
8. Walk to Judge and stop and remain for inspection, until dismissed.
9. The bridle may be dropped at the Judge's discretion.

### Reining Pattern 2:

End markers should be placed at least 75' from the center marker. Pattern area should be approximately 50' x 150' in size.

1. Run with speed, past center marker.
2. Stop and back up to center of pattern.
3. Settle horse for approximately ten seconds. Start lope. Circles should be made inside the end markers.
4. Ride two circles to the right, the first small and slow, the second large and fast.
5. Ride two circles to the left, the first small and slow, the second large and fast.
6. Left roll back over hocks (should be made past far end marker).
7. Right roll back over hocks (should be made past near end marker).
8. Stop (should be made past center marker). Let horse settle, then in appropriate area of stop, do the pivots.
9. Pivot right or left no more than 90 degrees.
10. Pivot opposite direction, no more than 180 degrees.
11. Walk to Judge and stop for inspection until dismissed.
12. The bridle may be dropped at the Judge's discretion.

### Reining Pattern #1

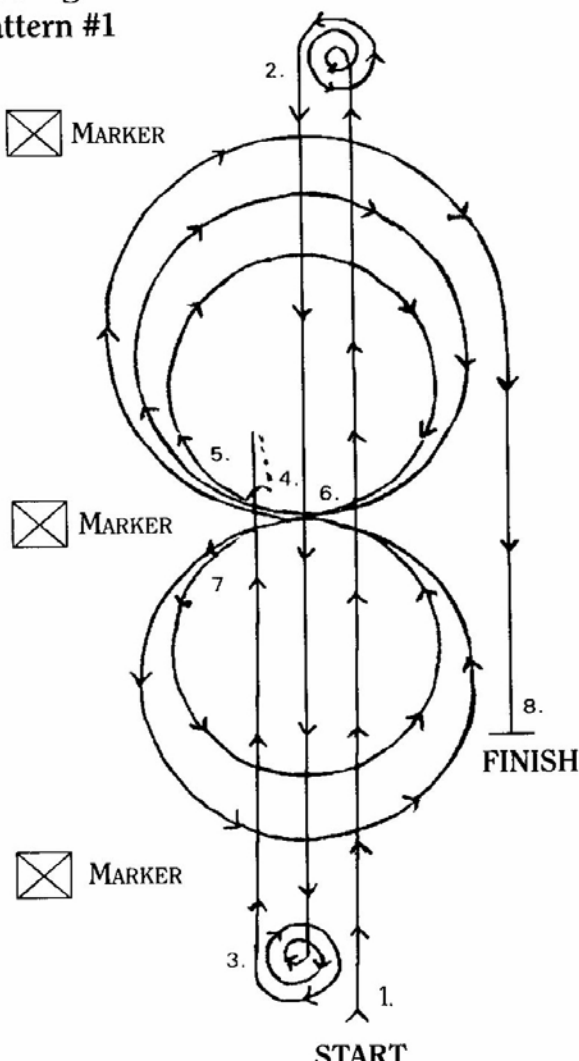

### Reining Pattern #2

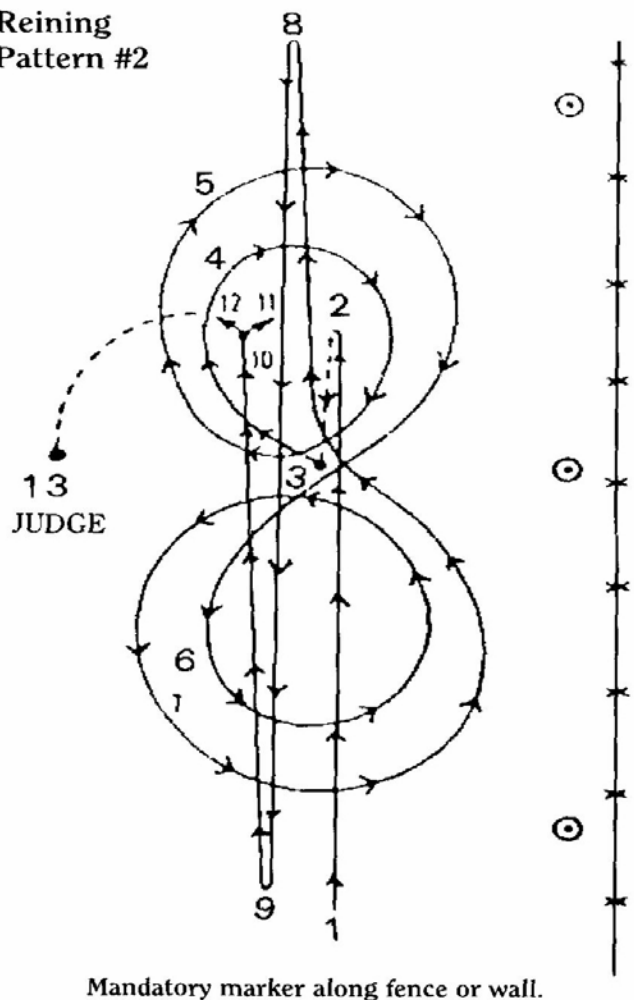

## Chapter 12: Versatility Class Descriptions and Specifications

### Reining Pattern 3:

End markers should be placed at least 75' from the center marker. Pattern area should be approximately 50' x 150' in size.

1. Run past center of arena and do a sliding stop.
2. Back immediately to center of arena, hesitate.
3. Do two spins to the right.
4. Do two and a quarter spins to the left, hesitate.
5. Beginning on left lead make a small, slow circle, then begin a large fast circle. Do not close this circle, but run straight down the side past center marker and do a right rollback at least 20 feet from fence or wall.
6. Continue back to center of arena, horse should be on right lead at center, make a small slow circle to the right, then begin a large fast circle. Do not close this circle, but run straight down the side past center and do a left roll back at least 20 feet from wall or fence.
7. Continue back to center of arena, horse should be on the left lead at center.
8. Make a large fast circle to the left at center of arena, change leads and make a large fast circle to the right at center of arena - change leads and begin a large, fast circle to the left. Do not close this circle but run straight down the side past the center marker and do a sliding stop at least 20 feet from the fence or wall.
9. Walk to Judge and stop for inspection until dismissed.
10. The bridle may be dropped at the Judge's discretion.

### Reining Pattern 4:

End markers should be placed at least 75' from the center marker. Pattern area should be approximately 50' x 150' in size.

1. Begin work to the right.
2. First figure eight, slow.
3. Second figure eight, faster (lead change must take place at Point A).
4. Proceed from Point B to Point C at flat walk or running walk.
5. Begin run.
6. Sliding stop.
7. Turn away from the rail, do a spin and a half, no hesitation.
8. Sliding stop.
9. Turn away from the rail do a spin and a half, no hesitation.
10. Sliding stop.
11. Back over slide marks. Face Judge, walk a few steps.
12. Pivot right or left, no more than 90 degrees.
13. Pivot the opposite direction, no more than 180 degrees.
14. Pivot in direction taken in instruction #12 above, no more than 180 degrees.
15. Walk to Judge and stop for inspection until dismissed.
16. The bridle may be dropped at the Judge's discretion.

### Reining Pattern #3

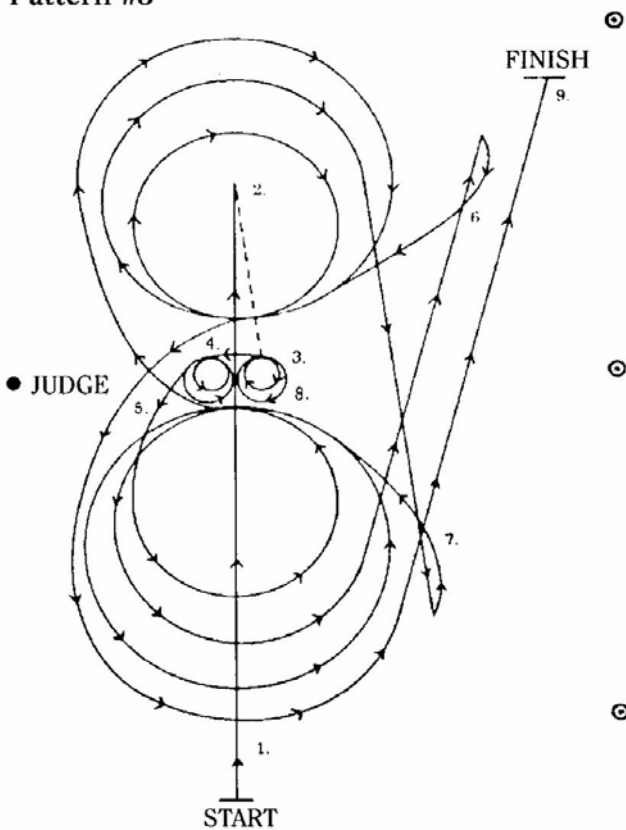

Mandatory marker along fence or wall.

### Reining Pattern #4

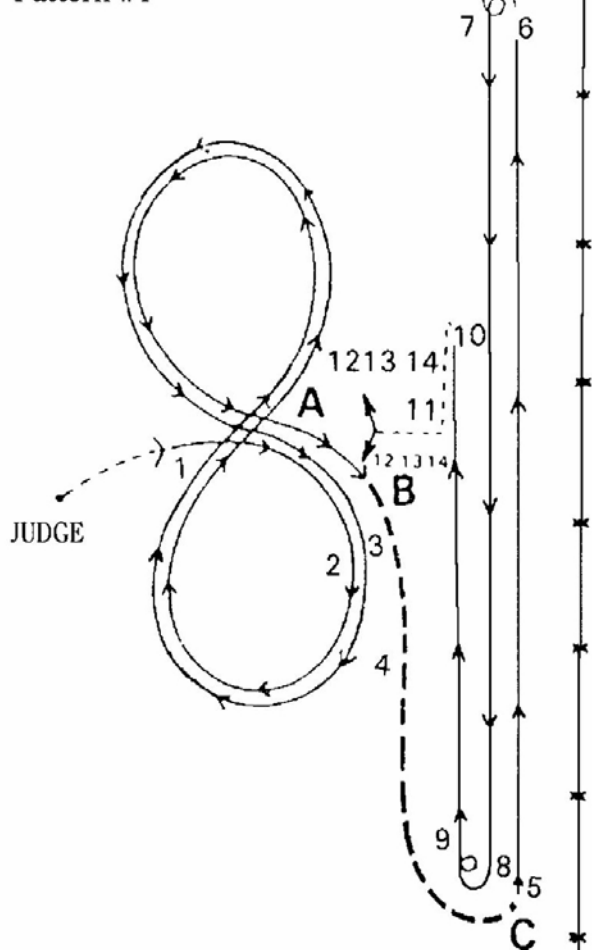

## Chapter 12: Versatility Class Descriptions and Specifications

### Reining Pattern 5:

End markers should be placed at least 75' from the center marker. Pattern area should be approximately 50' x 150' in size.

1. Starting in the center of the arena, make a large fast circle to the right.
2. Draw the circle down to a small circle until you reach the center of the arena, stop.
3. Do a double spin to the inside of the small circle in the center of the arena. At end of spins, horse should be facing the left wall, slight hesitation.
4. Begin on left lead and make a large, fast circle.
5. Then a small circle again drawing it down to the center of the arena – stop – no hesitation on these stops.
6. Do a double spin to the inside of the circle, slight hesitation – horse to be facing left wall.
7. Begin on right lead and make a fast figure eight over the large circles – and change leads.
8. Run to far end of arena and do a left roll back.
9. Run to opposite end of the arena and do a right roll back.
10. Run back past center of the arena and do a sliding stop. Hesitate.
11. Back over slide tracks.
12. Finish. Walk to Judge and stop for inspection until dismissed.
13. The bridle may be dropped at the Judge's discretion.

### Reining Pattern #5

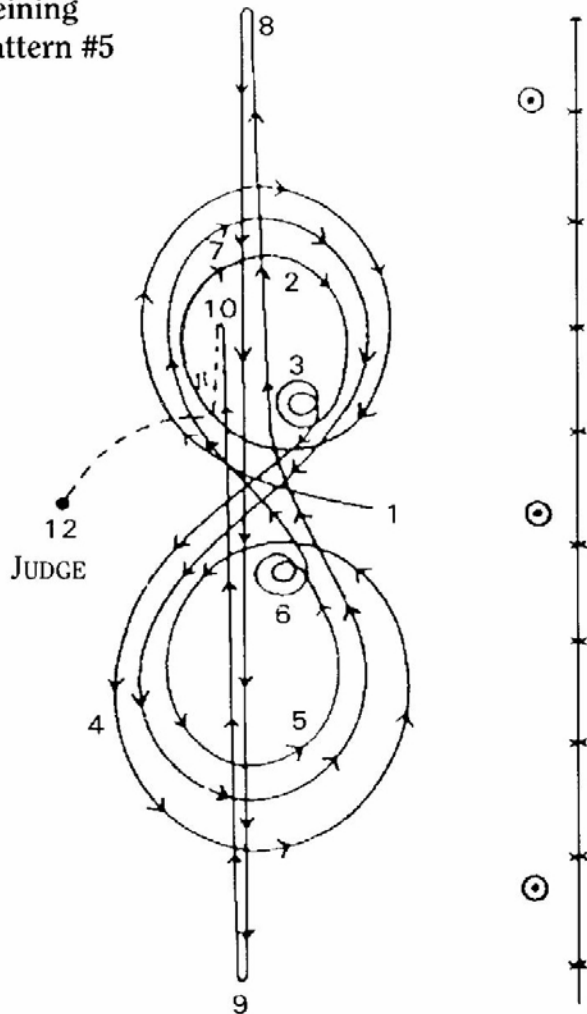

Mandatory Marker Along Fence or Wall.

### Reining Pattern 6:

End markers should be placed at least 75' from the center marker. Pattern area should be approximately 50' x 150' in size.

Begin pattern at center of the arena facing the left wall or fence.

1. Beginning on the right lead, complete three circles to the right: The first circle small and slow; the next two circles large and fast. Change leads at the center of the arena.
2. Complete three circles to the left: the first circle small and slow, the next two circles large and fast. Change leads at the center of the arena.
3. Run up the middle to the far end of the arena, past the end marker and do a left rollback – no hesitation.
4. Run to the opposite end of the arena past the end marker and do a right rollback – no hesitation.
5. Run past the center marker and do a sliding stop. Back up to the center of the arena or at least 10 feet. Hesitate.
6. Complete four spins to the right.
7. Complete four spins to the left. Hesitate to demonstrate the completion of the pattern.
8. Walk to Judge and stop for inspection until dismissed.
9. The bridle may be dropped at the Judge's discretion.

### Reining Pattern #6

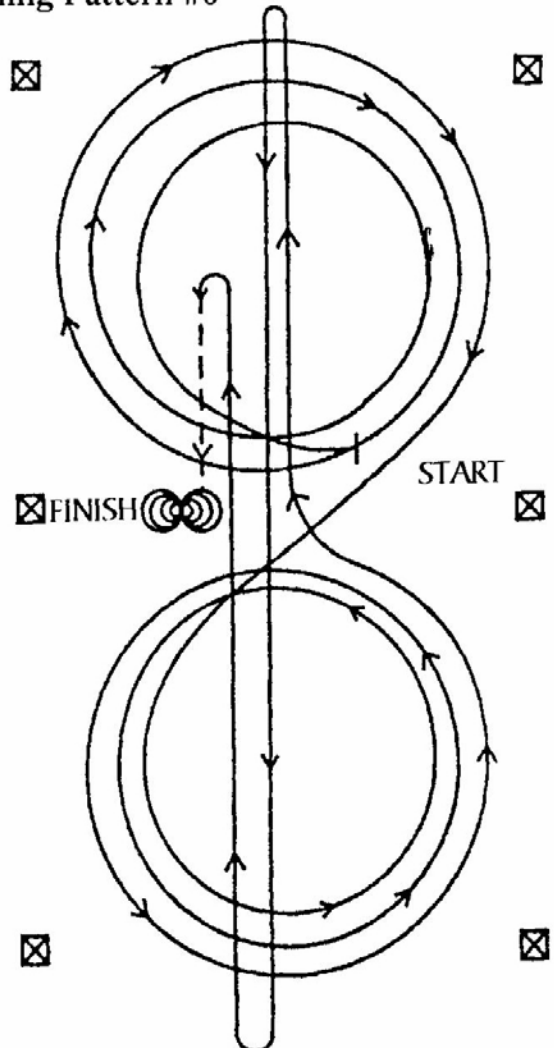

## Chapter 12: Versatility Class Descriptions and Specifications

### V114: Trail Obstacle

- The safety of the horse and rider is paramount with all obstacles.
- The construction and placement of the obstacles should not endanger horse or rider.
- The trail course should be posted at least one hour before the class. This class may be divided into specific divisions for youth, novice or adult.
- Each obstacle of the class shall be graded on a scale of one to ten basis, subtracting points for faults, refusals or excessive time. Judges should request an exhibitor to move to the next obstacle if too much time is spent on one obstacle.
- The course shall consist of at least six, but no more than ten obstacles. Three of the obstacles shall be “mandatory” (see list below). Final consideration of the Judge shall include quality and smoothness of performance of the horse and neatness and ability of the rider. The idea trail horse shall negotiate the course with surefootedness; looks at the obstacles, but does not hesitate, yet does not rush along the course. The horse should move willingly without excessive urging of the rider. Reins must be held in one hand and should not be changed during the performance. If ridden in English attire, the rider may have both hands on the reins.
- A time limit may be set for the course, however, the time itself shall have no bearing on the final placement, except as a limit for course completion.

#### Mandatory Obstacles: (three required)

- Opening, passing through and closing a gate. The gate should be constructed safely, and will not endanger horse or rider. Obstacle is not complete unless the gate is closed and should be judged accordingly. Changing of hands on gate or turning loose of gate is to be penalized.
- Ride over at least four logs or poles. Logs can be in a straight line, curved, zigzag or raised. The space between the logs it to be measured and the path the horse is to take should be measured. For walkovers, the spacing between poles should be 15 to 24 inches; for lope/canter overs the spacing should be 6 to 8 feet. The only elevated poles shall be for walk overs and they should be a minimum of 22 inches apart. Lope overs cannot be elevated. Elevated elements should be secured so they cannot roll.
- Ride over wooden bridge (may be plywood set so as to simulate sound and appearance of bridge). Suggested minimum width shall be 36” wide and at least 6’ long. Bridge should be sturdy and safe. Horses should navigate the bridge quietly without rushing on or off. Horses may be required to stop on the bridge.
- Ground tie horse, walking a full circle around the horse at least ten feet from the horse’s body.

#### Optional Obstacles:

- Back horse through “L” shaped course (logs, large poles or bales of hay suggested). On the ground: 28” minimum space between the poles; Elevated: 30” minimum between the poles.
- Water hazard.
- One jump not less than 14 nor more than 24 inches high to be ridden over.
- One jump not less than 14 nor more than 24 inches high to be led over.
- Pole on the ground to be side-passed, either direction or both directions
- Mailbox
- Canter a circle
- Exhibitor to put on and take off rain slicker while mounted
- Pick up and transfer object from one point to another (i.e. move a sack of cans from one barrel to another – barrels should be placed at least 12’ apart)

- Turn on the haunches or turn on the forehand in a designated area.

#### Tack and Attire

Either English or Western. Skid boots, polo wraps, splint boots, nonweighted bell boots, and combi boots are permitted. See 645 for Western Tack, Equipment and Attire. See 638 for Saddle Seat Tack, Equipment and Attire. See 608 for Prohibited Tack, Equipment and Attire.

#### Technical III Division

##### Technical Three

- Events or disciplines operated as stand alone events.
- Rules are not included for all events or disciplines.
- If Rules are not included, the event will be operated under the rules of the Governing Body for that Sport or Discipline.
- **Trail Trials, Judged Trail Rides, Competitive Trail, Endurance Rides, Ranch Horse Competition, Cattle Penning, Reining, Cutting, 3 Day Events, Cross Country Driving, Combined Driving.**

#### V115 Trail Trial

A competition designed to test the trail skills of a horse/rider team. Riders are judged and scored on their skill and ability to guide their horses through a natural obstacle course. Scores are ranked from lowest to highest with the lowest score denoting the winner.

#### General

- This is not a race.
- It is open to any breed of gaited horse or riding style
- A course may be several miles
- A course should reflect the diversity of the area
- It is a mounted event
- A horse may only be ridden by one rider
- Horses must be at least three [3] years of age
- Courses may be designed for Novice, Intermediate and Open competitors
- Copy of course provided each Competitor

#### Safety

- Common sense and safety are of prime importance.
- It is the rider’s responsibility to determine if his horse is capable of competing.
- Each rider is responsible for his own safety and the safety of his mount.
- Each rider must maintain control of their mount throughout the ride.
- Riding double, ponying an animal with or without a rider, or a loose foal on the side is not allowed.
- Ponying a horse as part of an obstacle shall not be allowed.

#### General

- The trail must be clearly marked.
- Obstacles are not arena style.
- Obstacles are those naturally encountered on a trail ride.
- Obstacles reflect riding conditions typical of the local environment with the goal being to maintain the character of an authentic trail ride.
- Whenever possible, a safe way of bypassing the obstacle will be provided.
- Overuse of inappropriately placed manmade materials designed only to increase the challenge (spook or startle) will not be allowed.

#### Equipment

- A halter with lead rope or halter bridle - mandatory
- A hoof pick - mandatory
- A knife capable of cutting lead rope, etc. – mandatory for adults.
- Any equipment not prohibited under IJA Rules. (see 608, 615)

## Chapter 12: Versatility Class Descriptions and Specifications

- Bareback pads - prohibited

### Attire:

- Boots with a heel - mandatory
- Any clothing suitable for riding
- Helmets - recommended

### Required Skills - may be used to negotiate Obstacles.

- Whoa - halt cues without argument.
- Stand quietly
- Execute gaits calmly and as directed
- Move the horse laterally [side to side]
- Turn on the forehand and/or hindquarters
- Back the horse in a straight line and/or around corners
- Back either horse's front or back feet over a raised object
- Emergency Dismount - kick both feet out of the stirrup before landing on the ground, while maintaining control of horse through contact with a rein.

### Obstacles

- Leading
- Ground handling the horse through challenging terrain etc
- Mounting
- Dismounting
- Hoof check
- Water crossing
- Uphill
- Downhill
- Steppover
- Bridge
- Gate
- Drag or Pull
- Standing tied
- Stationary Obstacles
- Moving Obstacles

### Judging:

- Senior Judge
- Judge at each obstacle

### Senior Judge - responsibility:

- Approve the course design by riding (on horseback) the course and obstacles the day of the event before the first competitor.
- Evaluate the course and obstacles to ensure:
  - safety for horse, rider and judges
  - the terrain relates to the skill level or competitors
  - space is adequate for multiple horses waiting to negotiate the obstacle.
  - Obstacles are placed so that the belongings of the Obstacle Judge are not part of the obstacle or impact the way of going of the participant.
- Instructs obstacle judges on judging their obstacles.
- Indicate exactly when and where judging will begin and end
- Interpret rules and make the final ruling.
- Disqualifies any participant from an obstacle or from the ride for unsportsmanlike conduct, or conduct that may reasonably result in physical harm to any person, animal or property.
- Signs the Official Results

### Procedure:

- To evaluate the way horse/rider team negotiates obstacle, a judge is located at each obstacle.
- Any obstacle judge may disqualify a participant from their obstacle for safety reasons.
- Competitor is judged only while negotiating obstacles.
- The obstacles must be executed as stated in the judge's directions.
- Obstacle Judge will mark the official score card for each

competitor using a standard scoring system.

### Standard scoring – value for each obstacle

- 0 - Perfect - no discernible mistakes
- 1 - Above average - very minor mistakes
- 2 - Adequate job - obvious mistakes
- 3 - Made an effort - skills need development
- 4 - No success: obstacle beyond team's skill level
- 24 - Bypassed obstacle
- 24 – Refusal - horse moves feet away from the obstacle.
  - Snorting and looking - not refusals.
  - 3 attempts allowed – 8 points per refusal
  - Cinch Check – when necessary and stated, failure to execute will be 2 points.
  - Jumping on, into, off of, through, or over any obstacle, unless required to do so, is a major fault.

### Protests – (See IJA Rules Chapter 7)